



NOISE STUDY

ACOUSTIC ASSESSMENT REPORT

**WOOLWICH BIO-EN INC.
ELMIRA, ONTARIO**

DISCLAIMER:
SOME FORMATTING CHANGES MAY HAVE OCCURRED WHEN
THE ORIGINAL DOCUMENT WAS PRINTED TO PDF; HOWEVER,
THE ORIGINAL CONTENT REMAINS UNCHANGED.

**NOVEMBER 2011
REF. NO. 046254 (5)**

**Prepared by:
Conestoga-Rovers
& Associates**

651 Colby Drive
Waterloo, Ontario
Canada N2V 1C2

Office: (519) 884-0510
Fax: (519) 884-0525

web: <http://www.CRAworld.com>

TABLE OF CONTENTS

	<u>Page</u>
1.0 INTRODUCTION	1
2.0 NOISE SOURCE SUMMARY	2
3.0 POINT-OF-RECEPTION SUMMARY	3
4.0 MANUFACTURER'S SOUND LEVEL DATA	4
5.0 ASSESSMENT CRITERIA	5
6.0 IMPACT ASSESSMENT	6
6.1 STEADY STATE NOISE SOURCES	6
6.2 PROPOSED NOISE CONTROL MEASURES	6
7.0 CONCLUSIONS	8

LIST OF FIGURES
(Following Text)

FIGURE 1	ACOUSTIC ASSESSMENT PLAN
FIGURE 2	POINT OF RECEPTION PLAN
FIGURE 3	SOUND IMPACT CONTOUR PLAN - DAY
FIGURE 4	SOUND IMPACT CONTOUR PLAN - NIGHT

LIST OF TABLES
(Following Text)

TABLE 1	NOISE SOURCE SUMMARY
TABLE 2A	POINT-OF-RECEPTION NOISE IMPACT - UNATTENUATED SOUND LEVELS
TABLE 2B	POINT-OF-RECEPTION NOISE IMPACT - ATTENUATED SOUND LEVELS
TABLE 3	ACOUSTIC ASSESSMENT SUMMARY - STEADY-STATE SOUND LEVELS

LIST OF APPENDICES

APPENDIX A	ZONING MAP
APPENDIX B	NOISE SPECIFICATION AND WORST-CASE SIMULTANEOUS OPERATIONS SUMMARY
APPENDIX C	INSIGNIFICANT NOISE SUMMARY TABLE
APPENDIX D	CADNA A MODEL OUTPUT FILE AND CD

1.0 INTRODUCTION

Conestoga-Rovers & Associates (CRA) was retained to prepare an Acoustic Assessment Report (Assessment) for the Woolwich Bio-En Inc. (Bio-En) anaerobic digestion (AD) facility (Facility) located at 40 Martin's Lane (Plan 58R-14363, Lot 18, Part 9) in Elmira Ontario. The Assessment has been prepared as the Noise Study required by Ontario Regulation 359/09 (O. Reg. 359/09) in support of Bio-En's Application for Renewable Energy Approval (REA) since the Facility does not meet the minimum required separation distance to the nearest off-site sensitive point-of-reception defined using the Ontario Ministry of the Environment (MOE) Noise Screening process.

The Facility produces biogas from a variety of organic materials that may include manure, kitchen waste, fats, oils and greases, farm crop waste and other organic materials. The Facility operates up to 24 hours per day, seven days per week, 52 weeks per year.

The Assessment presented herein provides an evaluation of the potential noise impacts from Facility noise emissions generated during normal operations on the sensitive receptors located nearest to the Facility. The Assessment was prepared consistent with the following MOE guidance:

- NPC-233, *"Information to be Submitted for Approval of Stationary Sources of Sound, October 1995"*
- *"Appendix A – Supporting Information for an Acoustic Assessment Report or Vibration Assessment Report Required by a Basic Comprehensive C of A"* as specified in the MOE guidance entitled *"Basic Comprehensive Certificates of Approval (Air) – User Guide, April 2004"*
- NPC-205, *"Sound Level Limits for Stationary Sources in Class 1 and 2 Areas (Urban), October 1995"*
- NPC-103, *"Procedures, August 1978"*

The Facility is located on General Industrial (M-1) zoned land and is surrounded by land zoned General Industrial (M-1) and Agricultural (A) zoned land. A zoning map and definitions are provided in Appendix A. An elevation plan for the Facility is provided on Figures A.2 and A.3

The Facility is located in an Acoustical Class 2 area defined by NPC-205 as a mixed acoustic environment with elevated daytime noise levels due to surrounding industrial activity and lower background noise levels during the nighttime period.

2.0 NOISE SOURCE SUMMARY

This Assessment focused on the sound emissions from the noise sources identified at the Facility with a potential to adversely impact the sensitive receptors. The Noise Source Summary is provided in Table 1 and the significant noise source locations are identified on Figure 1. Based on information supplied by Bio-En the following significant noise sources have been identified by their Cadna modelling ID number:

- Two (2) engines stacks (S1A and S1B)
- Two (2) Biofilter fans (S2A and S2B)
- Fourteen (14) Agitators (S4-S17)
- Two (2) Radiators (S18A and S18B)
- Two (2) Engine room discharges (S19A and S19B)
- Two (2) Engine room air intakes (S20A and S20B)
- One Transformer (S21)
- Truck Traffic (T1)

There are no sources of impulse noise or vibration at the Facility.

Manufacturer's specifications for the equipment listed above are provided in Appendix B.

The other noise sources at the Facility have not been included since they are considered insignificant contributors to the overall Facility noise level at the sensitive receptors as summarized in Table C.1 of Appendix C.

3.0 POINT-OF-RECEPTION SUMMARY

The identification of appropriate sensitive point(s)-of-reception is necessary to conduct the Assessment for the Facility. A "point-of-reception" is any point on the premises of a person where sound, originating from other than those premises, is received. The point-of-reception may be located on permanent or seasonal residences, hotels/motels, nursing/retirement homes, rental residences, hospitals, campgrounds, parks, schools, cemeteries or places of worship.

The objective of this Assessment is to determine the predictable worst-case 1-hour equivalent sound level (1-hour Leq) at the worst-case point(s)-of-reception. The worst-case point(s)-of-reception is (are) defined as the sensitive receptor(s) with the greatest potential exposure to the Facility noise sources due to proximity and direct line-of-sight exposure.

The worst-case sensitive point(s)-of-reception (POR) are:

- POR1 - Arthur Street Residence, assumed two-story (4.5 m above grade [AG])
- POR2 - High Street Residence, assumed two-story (4.5 m AG)
- POR3 - Township Road 14 Residence, assumed two-story (4.5 m AG)

The locations of the worst-case PORs are identified on Figure 2. All POR locations identified on Figure 2 were evaluated, however only the noise impact at the worst-case and most exposed POR(s) is presented herein.

4.0 MANUFACTURER'S SOUND LEVEL DATA

Manufacturer's sound power level data and CRA's extensive library of noise measurements were used to assess the significant noise sources operated at the Facility.

The noise emitted from the engine exhausts and engine room air intakes and discharges were modelled using manufacturer specifications as point sources. The engine exhausts, intakes and discharges are equipped with silencers.

The sound level from the flare was insignificant as per the manufacturers' specifications.

The noise emitted from the truck traffic was based on CRA's extensive library of noise measurements. Since various makes and models of trucks will be transporting material into the Facility the maximum sound level of a moving 18-wheeler tractor/trailer from CRA's noise library was used. The noise emitted from the trucks was based on a height of 2 metres.

The truck traffic was modelled as a line source following the roads within the Facility. It was estimated that the trucks would travel at a maximum of 10 km/hr and there would be a maximum of twenty truck movements per hour during the daytime and two truck movements per hour during the nighttime. Two movements is equivalent to one truck onsite due to the set-up of the weigh bridges; each truck must travel along the path twice. The sound from trucks loading/unloading is considered insignificant compared to the facility-wide sound levels since it occurs inside the operation building.

The agitators are mechanical devices used to mix the pretreatment tanks, main digester tanks, and secondary digester and repository tank. The motors of the agitators are located on the top of the pretreatment tanks at a height of 5.78 metres for Agitators 11-13 and Agitator 17 (Sources S14 - S17). The agitators for the digester tanks (Sources S4 - S13) are located on the side of the tanks at a height of 7.0 metres.

The noise emitted from the radiators (Sources S18A and S18B) are based on manufacturers specifications.

The noise emitted from the transformer is based on manufacturer specifications and transformer sound power calculations as detailed in Table B.2 of Appendix B. A tonal penalty of 5 dB was applied to the transformer.

Manufacturer noise specifications for the above equipment and silencers are provided in Appendix B.

5.0 ASSESSMENT CRITERIA

Assessment criteria may be determined for a point-of-reception based on the MOE's minimum exclusionary sound level limits, as presented in Table 205-1 of NPC-205, in comparison to the background sound levels experienced in the area. The "background sound level" is defined as the sound level present in the environment that is produced by noise sources other than those from the Facility, and would include traffic sound levels and sound from neighboring industrial/commercial activity. The higher of the two assessment criteria is selected for purpose of assessment.

The Facility is located in an Acoustic Class 2 Area. Class 2 Areas have the following generic minimum sound level limits expressed as a 1-hour Leq that can be applied to assess the sound levels emitted by the Facility noise sources:

<i>Time of Day</i>	<i>Minimum Exclusionary Sound Level</i>
7:00 a.m. to 7:00 p.m.	50 dBA
7:00 p.m. to 7:00 a.m.	45 dBA

Since a background sound level evaluation was not conducted for this site to justify higher site-specific limits, the minimum MOE exclusionary sound level limits were selected as the noise criteria for purposes of this Assessment.

6.0 IMPACT ASSESSMENT

6.1 STEADY STATE NOISE SOURCES

The worst-case assessment of steady state noise sources at the selected point(s)-of-reception was based on measured reference sound pressure levels and distances and representative noise specifications. Cadna A Acoustical Modeling Software (Cadna A), version 4.1, was used to model the potential impacts of the significant noise sources. Cadna A calculates sound level emissions based on the ISO 9613-2 standard. The worst-case cumulative facility-wide sound levels estimated at the receptor(s) included attenuation effects due to geometric divergence, atmospheric attenuation, barriers/berms, ground absorption and directivity, as applicable for all significant noise sources.

Buildings and large tanks were modelled as a reflective surface and indirect line-of-sight noise impacts were evaluated.

The unattenuated sound levels estimated at the worst-case points-of-reception are summarized in Table 2A.

6.2 PROPOSED NOISE CONTROL MEASURES

Based on the results presented in Table 2A, the implementation of noise control measures will be required to ensure compliance with MOE noise guidelines. An option to adhere includes the installation of silencers on select equipment (Sources S1A, S1B, S19A, S19B, S20A, and S20B). Table B.1 located in Appendix B summarizes the insertion loss requirements. Appendix B also provides manufacturers specifications for the silencers.

The attenuated sound levels estimated at the worst-case points-of-reception are summarized in Table 2B. The attenuated Sound Impact Contour Plan is provided in Figures 3 and 4 for daytime and nighttime, respectively.

The required mitigation for the Facility to be in compliance with NPC-205 is relatively simple. Therefore CRA found that a detailed Noise Abatement Action Plan is not necessary.

The Cadna A model output files for both unattenuated and attenuated scenarios for POR1 are provided in Appendix D.

Table 3 provides a summary of the overall predicted noise levels at the identified PORs. With the implementation of the proposed mitigation measures the predicted sound levels at the identified PORs are at or below the performance limits.

7.0 CONCLUSIONS

It was determined that the applicable sound levels (performance limits) are exceeded for the existing operations. With the implementation of recommended mitigation measures specified in Section 6.2 the predicted Facility noise impact at the identified PORs will be in compliance with MOE noise limits as summarized in Table 3.

Bio-En accepts the obligation to implement the proposed noise measures before the Facility is fully operational.

CRA recommends that any future equipment contribute less than 30 dBA at the applicable point(s)-of-reception.

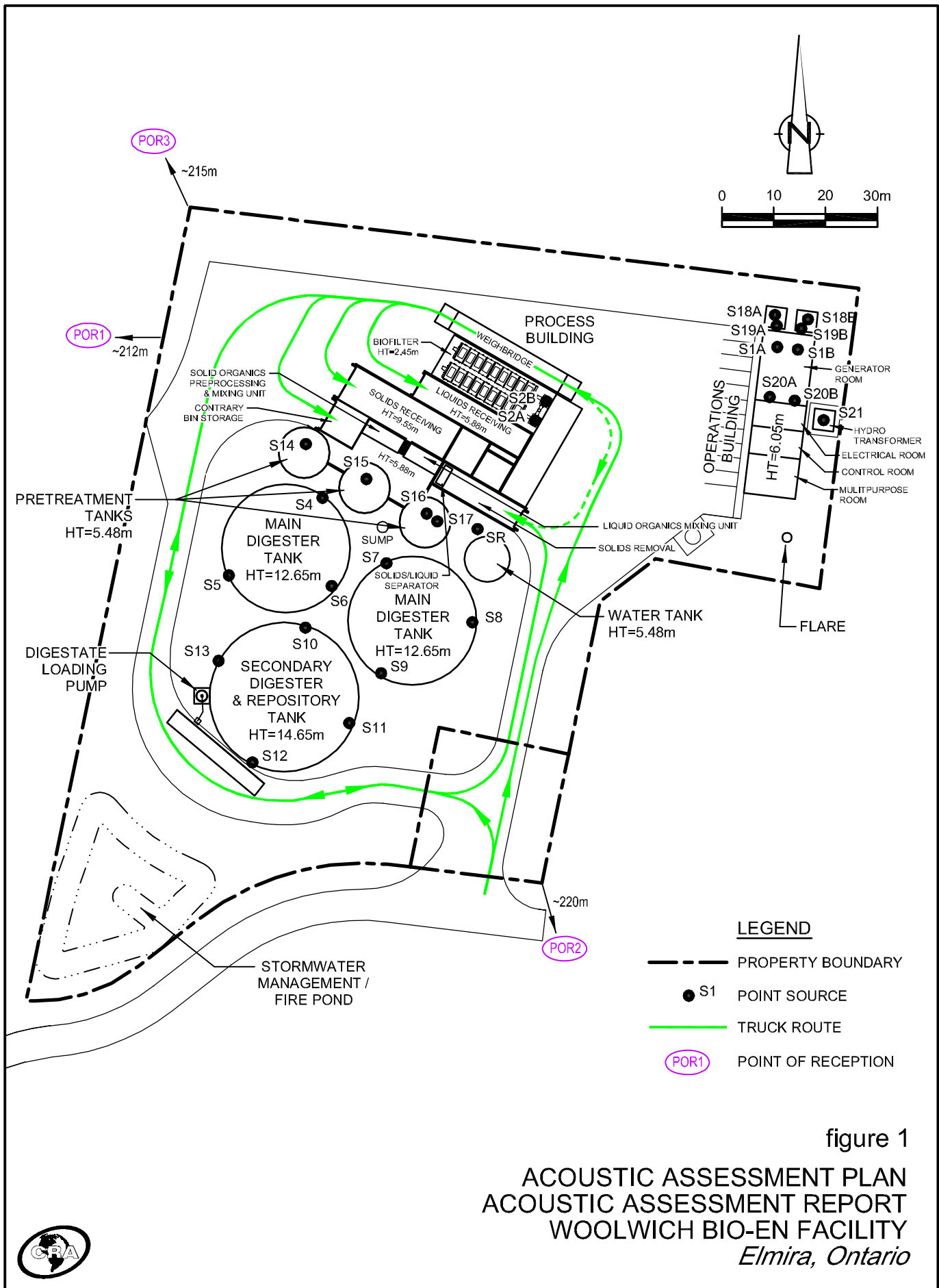

figure 1
 ACOUSTIC ASSESSMENT PLAN
 ACOUSTIC ASSESSMENT REPORT
 WOOLWICH BIO-EN FACILITY
 Elmira, Ontario



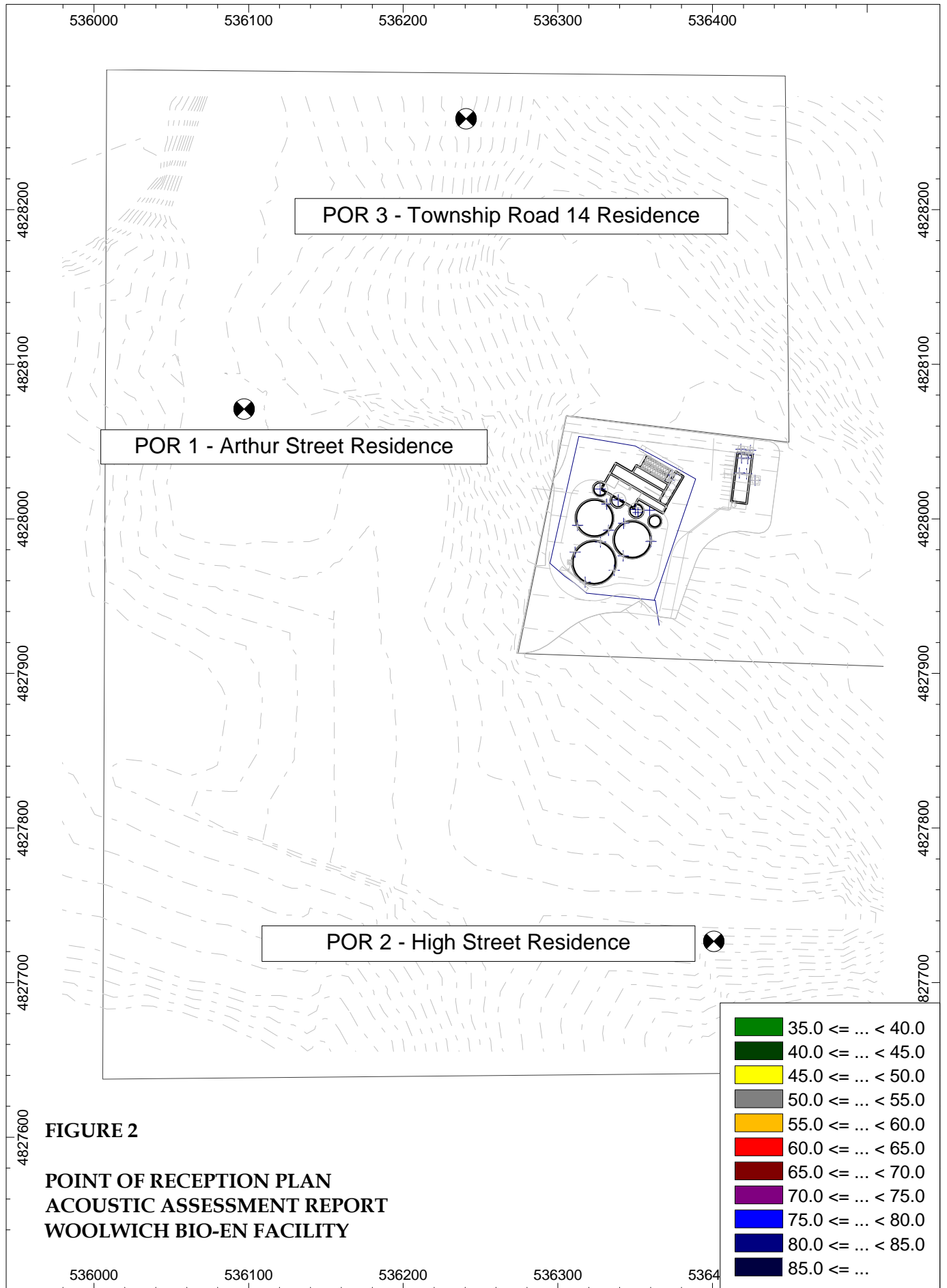
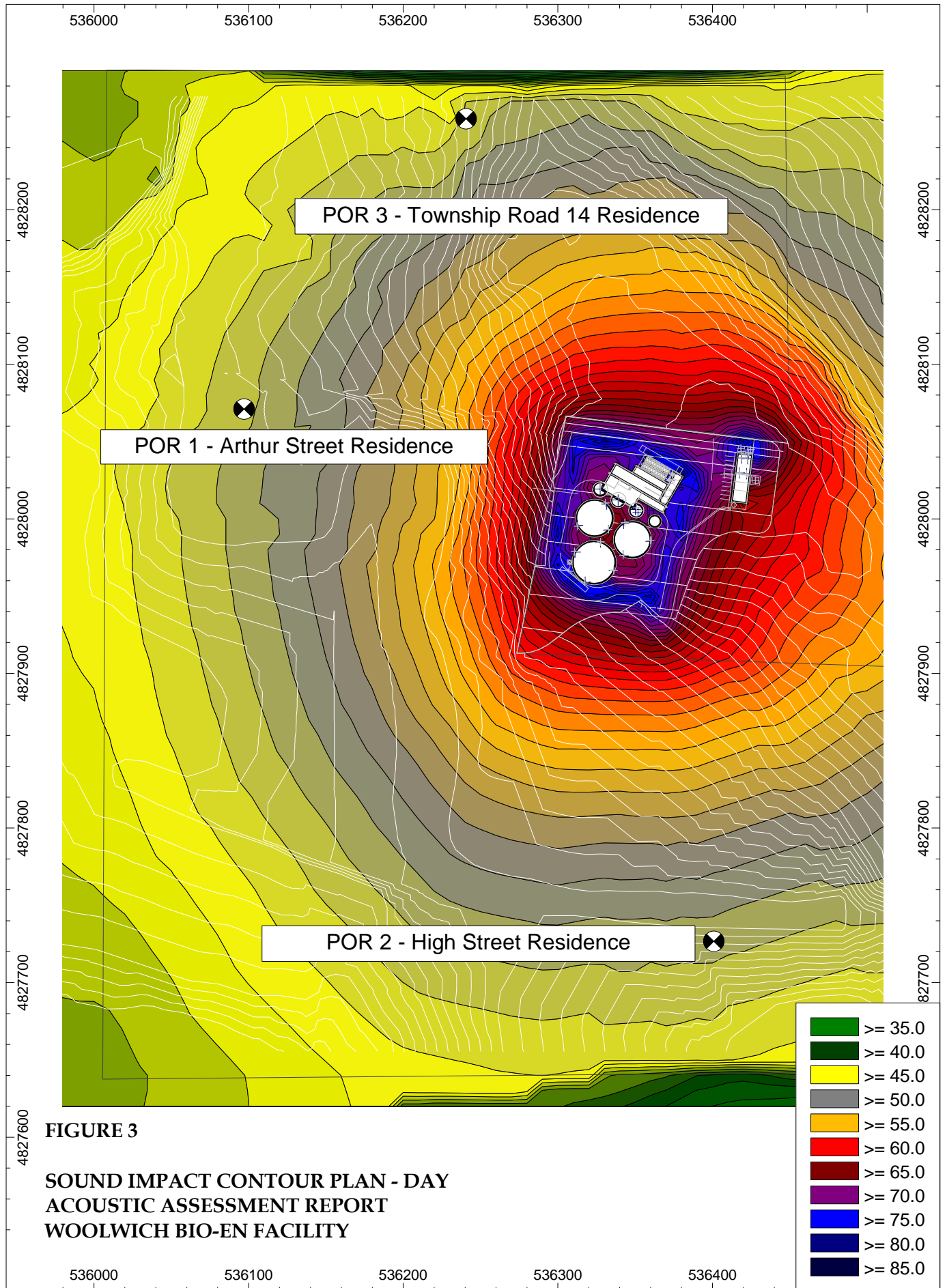

FIGURE 2

**POINT OF RECEPTION PLAN
ACOUSTIC ASSESSMENT REPORT
WOOLWICH BIO-EN FACILITY**



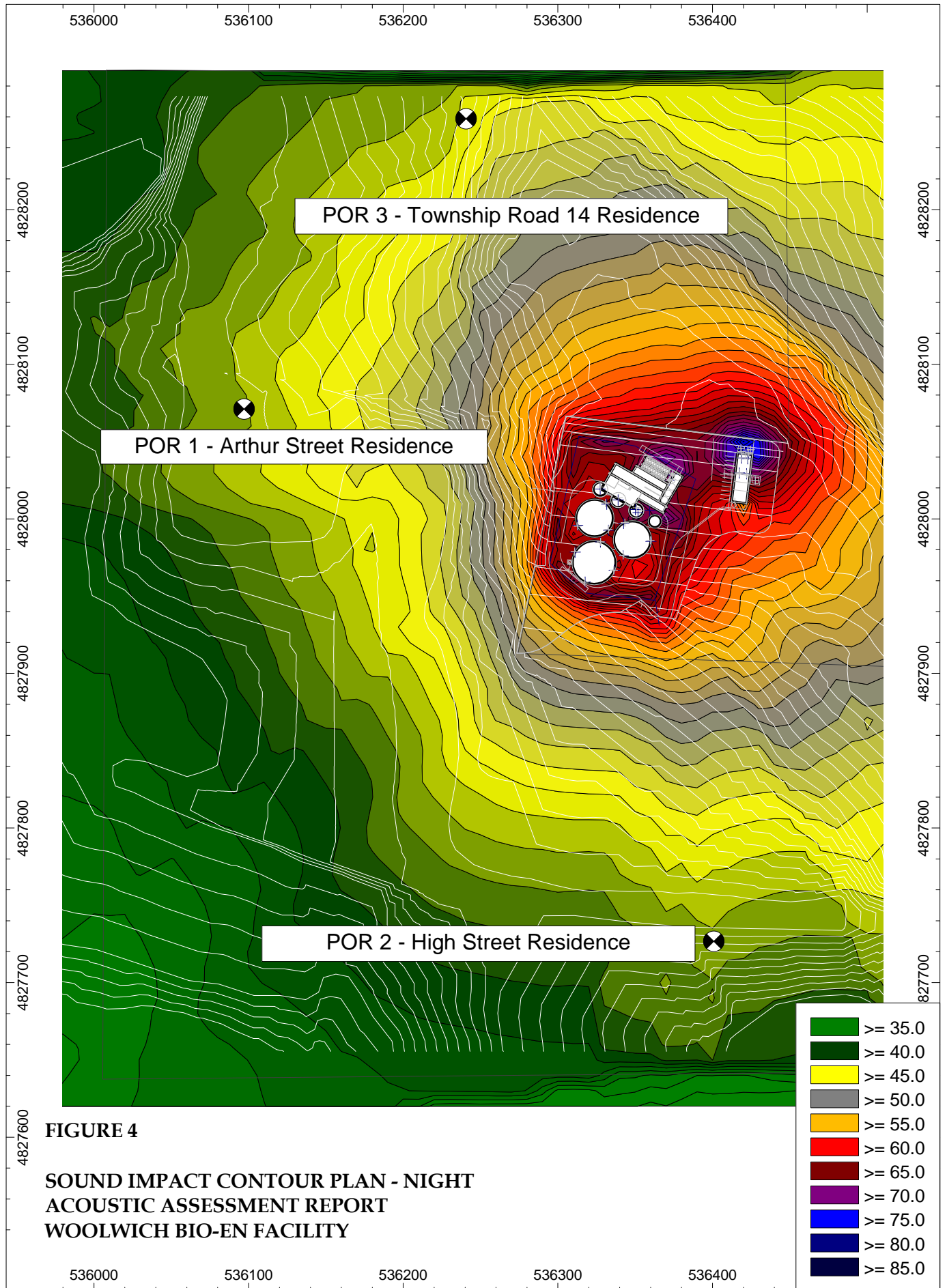

FIGURE 4

**SOUND IMPACT CONTOUR PLAN - NIGHT
ACOUSTIC ASSESSMENT REPORT
WOOLWICH BIO-EN FACILITY**

TABLE 1

**NOISE SOURCE SUMMARY
WOOLWICH BIO-EN INC.
ELMIRA, ONTARIO**

<i>Cadna A ID</i>	<i>Source Description</i>	<i>Type of Noise Source</i>	<i>Uncontrolled Sound Power Level (1) (dBA)</i>	<i>Source Location (2)</i>	<i>Sound Characteristics (3)</i>	<i>Noise Control Measures (4)</i>
S1A	Engine # 1	Point Source	126	O	S	S
S1B	Engine # 2	Point Source	126	O	S	S
S2A	Biofilter fan	Point Source	94.8	O	S	U
S2B	Biofilter fan	Point Source	94.8	O	S	U
S4	Agitator 1	Point Source	82	O	S	U
S5	Agitator 2	Point Source	82	O	S	U
S6	Agitator 3	Point Source	82	O	S	U
S7	Agitator 4	Point Source	82	O	S	U
S8	Agitator 5	Point Source	82	O	S	U
S9	Agitator 6	Point Source	82	O	S	U
S10	Agitator 7	Point Source	82	O	S	U
S11	Agitator 8	Point Source	82	O	S	U
S12	Agitator 9	Point Source	82	O	S	U
S13	Agitator 10	Point Source	82	O	S	U
S14	Agitator 11	Point Source	93	O	S	U
S15	Agitator 12	Point Source	93	O	S	U
S16	Agitator 13	Point Source	93	O	S	U
S17	Agitator 17	Point Source	93	O	S	U
S18A	Radiator	Point Source	97	O	S	U
S18B	Radiator	Point Source	97	O	S	U
S19A	Discharge	Point Source	102.6	O	S	S
S19B	Discharge	Point Source	102.6	O	S	S
S20A	Intake	Point Source	102.6	O	S	S
S20B	Intake	Point Source	102.6	O	S	S
SR	Radiator	Point Source	97	O	S	U
T1	Truck Route	Line Source	97.8	O	S	U

Notes:

(1) Sound Power Level (PWL) in dBA calculated from sound pressure level and reference distance.

(2) Source Location:

- O - located/installed outside of building
- I - located/installed inside of building

(3) Sound Characteristics:

- S - Steady
- Q - Quasi Steady Impulsive
- I - Impulsive
- B - Buzzing
- T - Tonal
- C - Cyclic

(4) Noise Control Measures:

- S - silencer, acoustic louvre, muffler
- A - acoustic lining, plenum
- B - barrier, berm, screening
- L - lagging
- E - acoustic enclosure
- O - other
- U - uncontrolled
- AC - administrative control

TABLE 2A

POINT-OF-RECEPTION NOISE IMPACT - UNATTENUATED SOUND LEVELS
WOOLWICH BIO-EN INC.
ELMIRA, ONTARIO

<i>Cadna A Source ID</i>	<i>Significant Noise Source Description</i>	<i>Arthur Street Residence - POR1</i>		<i>High Street Residence - POR2</i>		<i>Township Road 14 Residence - POR3</i>	
		<i>Sound Level at Receptor (1) Day (Leq)</i>	<i>Sound Level at Receptor (1) Night (Leq)</i>	<i>Sound Level at Receptor (1) Day (Leq)</i>	<i>Sound Level at Receptor (1) Night (Leq)</i>	<i>Sound Level at Receptor (1) Day (Leq)</i>	<i>Sound Level at Receptor (1) Night (Leq)</i>
S1A	Engine # 1	61.3 dBA	61.3 dBA	61.7 dBA	61.7 dBA	64.1 dBA	64.1 dBA
S1B	Engine # 2	61.2 dBA	61.2 dBA	61.8 dBA	61.8 dBA	63.9 dBA	63.9 dBA
S2A	Biofilter fan	26.4 dBA	26.4 dBA	25.8 dBA	25.8 dBA	33.5 dBA	33.5 dBA
S2B	Biofilter fan	28.4 dBA	28.4 dBA	29.1 dBA	29.1 dBA	35.8 dBA	35.8 dBA
S4	Agitator 1	14.0 dBA	14.0 dBA	7.0 dBA	7.0 dBA	22.4 dBA	22.4 dBA
S5	Agitator 2	23.5 dBA	23.5 dBA	5.0 dBA	5.0 dBA	17.3 dBA	17.3 dBA
S6	Agitator 3	22.9 dBA	22.9 dBA	22.3 dBA	22.3 dBA	22.0 dBA	22.0 dBA
S7	Agitator 4	6.4 dBA	6.4 dBA	3.8 dBA	3.8 dBA	17.2 dBA	17.2 dBA
S8	Agitator 5	2.3 dBA	2.3 dBA	22.7 dBA	22.7 dBA	-0.7 dBA	-0.7 dBA
S9	Agitator 6	11.5 dBA	11.5 dBA	25.3 dBA	25.3 dBA	-1.6 dBA	-1.6 dBA
S10	Agitator 7	23.0 dBA	23.0 dBA	5.3 dBA	5.3 dBA	2.5 dBA	2.5 dBA
S11	Agitator 8	3.0 dBA	3.0 dBA	23.0 dBA	23.0 dBA	-1.3 dBA	-1.3 dBA
S12	Agitator 9	18.2 dBA	18.2 dBA	23.0 dBA	23.0 dBA	4.8 dBA	4.8 dBA
S13	Agitator 10	23.4 dBA	23.4 dBA	6.9 dBA	6.9 dBA	21.6 dBA	21.6 dBA
S14	Agitator 11	34.3 dBA	34.3 dBA	15.6 dBA	15.6 dBA	36.3 dBA	36.3 dBA
S15	Agitator 12	33.4 dBA	33.4 dBA	19.6 dBA	19.6 dBA	23.9 dBA	23.9 dBA
S16	Agitator 13	29.2 dBA	29.2 dBA	33.2 dBA	33.2 dBA	19.2 dBA	19.2 dBA
S17	Agitator 17	28.0 dBA	28.0 dBA	32.1 dBA	32.1 dBA	19.3 dBA	19.3 dBA
S18A	Radiator	32.4 dBA	32.4 dBA	24.5 dBA	24.5 dBA	31.8 dBA	31.8 dBA
S18B	Radiator	32.3 dBA	32.3 dBA	26.7 dBA	26.7 dBA	35.7 dBA	35.7 dBA
S19A	Discharge	37.7 dBA	37.7 dBA	26.3 dBA	26.3 dBA	41.8 dBA	41.8 dBA
S19B	Discharge	37.6 dBA	37.6 dBA	26.6 dBA	26.6 dBA	41.7 dBA	41.7 dBA
S20A	Intake	41.7 dBA	41.7 dBA	37.6 dBA	37.6 dBA	42.1 dBA	42.1 dBA
S20B	Intake	41.6 dBA	41.6 dBA	37.6 dBA	37.6 dBA	42.0 dBA	42.0 dBA
SR	Radiator	25.1 dBA	25.1 dBA	31.8 dBA	31.8 dBA	17.7 dBA	17.7 dBA
T1	Truck Route	46.5 dBA	36.5 dBA	47.4 dBA	37.4 dBA	44.8 dBA	34.8 dBA
Worst-case Facility-wide Total Sound Level (One-hour Leq):		64.4 dBA	64.4 dBA	64.9 dBA	64.8 dBA	67.1 dBA	67.1 dBA

Notes:

- (1) Sound Level at the Receptor was calculated using Cadna A Acoustical Modelling Software.
- (2) Refer to CadnaA model for distance to receptor

TABLE 2B

POINT-OF-RECEPTION NOISE IMPACT - ATTENUATED SOUND LEVELS
WOOLWICH BIO-EN INC.
ELMIRA, ONTARIO

Cadna A Source ID	Significant Noise Source Description	Arthur Street Residence - POR1		High Street Residence - POR2		Township Road 14 Residence - POR3	
		Sound Level at Receptor (1)	Sound Level at Receptor (1)	Sound Level at Receptor (1)	Sound Level at Receptor (1)	Sound Level at Receptor (1)	Sound Level at Receptor (1)
		Day (Leq)	Night (Leq)	Day (Leq)	Night (Leq)	Day (Leq)	Night (Leq)
S1A	Engine # 1	32.4 dBA	32.4 dBA	33.1 dBA	33.1 dBA	33.8 dBA	33.8 dBA
S1B	Engine # 2	32.3 dBA	32.3 dBA	33.1 dBA	33.1 dBA	33.7 dBA	33.7 dBA
S2A	Biofilter fan	27.0 dBA	27.0 dBA	20.4 dBA	20.4 dBA	35.5 dBA	35.5 dBA
S2B	Biofilter fan	28.2 dBA	28.2 dBA	21.8 dBA	21.8 dBA	38.3 dBA	38.3 dBA
S4	Agitator 1	14.0 dBA	14.0 dBA	7.0 dBA	7.0 dBA	22.4 dBA	22.4 dBA
S5	Agitator 2	23.5 dBA	23.5 dBA	5.0 dBA	5.0 dBA	17.3 dBA	17.3 dBA
S6	Agitator 3	22.9 dBA	22.9 dBA	22.3 dBA	22.3 dBA	22.0 dBA	22.0 dBA
S7	Agitator 4	6.4 dBA	6.4 dBA	3.8 dBA	3.8 dBA	17.2 dBA	17.2 dBA
S8	Agitator 5	2.3 dBA	2.3 dBA	22.7 dBA	22.7 dBA	-1.1 dBA	-1.1 dBA
S9	Agitator 6	11.5 dBA	11.5 dBA	25.3 dBA	25.3 dBA	-1.7 dBA	-1.7 dBA
S10	Agitator 7	23.0 dBA	23.0 dBA	5.3 dBA	5.3 dBA	2.3 dBA	2.3 dBA
S11	Agitator 8	3.0 dBA	3.0 dBA	23.0 dBA	23.0 dBA	-1.4 dBA	-1.4 dBA
S12	Agitator 9	18.2 dBA	18.2 dBA	23.0 dBA	23.0 dBA	4.8 dBA	4.8 dBA
S13	Agitator 10	23.4 dBA	23.4 dBA	6.9 dBA	6.9 dBA	21.6 dBA	21.6 dBA
S14	Agitator 11	34.3 dBA	34.3 dBA	15.4 dBA	15.4 dBA	36.3 dBA	36.3 dBA
S15	Agitator 12	33.4 dBA	33.4 dBA	19.6 dBA	19.6 dBA	23.9 dBA	23.9 dBA
S16	Agitator 13	29.2 dBA	29.2 dBA	33.2 dBA	33.2 dBA	14.8 dBA	14.8 dBA
S17	Agitator 17	28.0 dBA	28.0 dBA	32.1 dBA	32.1 dBA	14.9 dBA	14.9 dBA
S18A	Radiator	32.4 dBA	32.4 dBA	32.1 dBA	32.1 dBA	31.8 dBA	31.8 dBA
S18B	Radiator	32.3 dBA	32.3 dBA	27.2 dBA	27.2 dBA	35.7 dBA	35.7 dBA
S19A	Discharge	5.7 dBA	5.7 dBA	-4.7 dBA	-4.7 dBA	9.8 dBA	9.8 dBA
S19B	Discharge	5.6 dBA	5.6 dBA	-4.9 dBA	-4.9 dBA	9.7 dBA	9.7 dBA
S20A	Intake	8.7 dBA	8.7 dBA	9.4 dBA	9.4 dBA	9.2 dBA	9.2 dBA
S20B	Intake	8.6 dBA	8.6 dBA	4.6 dBA	4.6 dBA	9.1 dBA	9.1 dBA
SR	Radiator	25.1 dBA	25.1 dBA	32.0 dBA	32.0 dBA	16.0 dBA	16.0 dBA
T1	Truck Route	46.5 dBA	36.5 dBA	47.6 dBA	37.6 dBA	44.6 dBA	34.6 dBA
Worst-case Facility-wide Total Sound Level (One-hour Leq):		47.8 dBA	43.0 dBA	48.5 dBA	42.7 dBA	47.4 dBA	44.5 dBA

Notes:

- (1) Sound Level at the Receptor was calculated using Cadna A Acoustical Modelling Software.
- (2) Refer to CadnaA model for distance to receptor

TABLE 3

ACOUSTIC ASSESSMENT SUMMARY - ATTENUATED STEADY STATE SOUND LEVELS
 WOOLWICH BIO-EN INC.
 ELMIRA, ONTARIO

<i>Point-of-Reception ID</i>	<i>Point-of-Reception Description</i>	<i>Unattenuated Sound Level at Point-of-Reception Predicted (Leq)</i>	<i>Verified by Acoustic Audit (Yes/No) ⁽²⁾</i>	<i>Performance Limit ⁽¹⁾ (Leq)</i>	<i>Compliance with Performance Limit (Yes/No)</i>
POR1	Arthur Street Residence (Day)	47.8 dBA	No	50 dBA	Yes
	Arthur Street Residence (Night)	43.0 dBA	No	45 dBA	Yes
POR2	High Street Residence (Day)	48.5 dBA	No	50 dBA	Yes
	High Street Residence (Night)	42.7 dBA	No	45 dBA	Yes
POR3	Township Road 14 Residence (Day)	47.4 dBA	No	50 dBA	Yes
	Township Road 14 Residence (Night)	44.5 dBA	No	45 dBA	Yes

Note:

- (1) NPC-205 minimum exclusionary noise limits.
- (2) Facility is not operational

APPENDIX A

ZONING MAP

MAP SYMBOL CLASSIFICATION

- A AGRICULTURAL
- R-1 RESIDENTIAL - SETTLEMENT
- R-4 RESIDENTIAL - MIXED MEDIUM DENSITY
- R-6 RESIDENTIAL - COMMERCIAL
- C-1 CORE COMMERCIAL - URBAN
- M-1 GENERAL INDUSTRIAL - DRY
- O-1 OPEN SPACE
- P INSTITUTIONAL

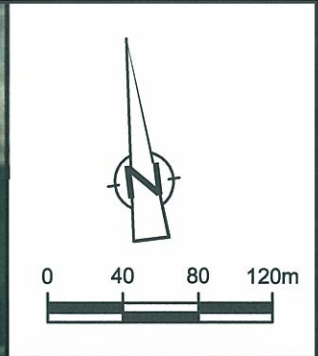

LEGEND
 (POR1) POINT OF RECEPTION

figure A.1
 LAND USE ZONING DESIGNATION PLAN
 ACOUSTIC ASSESSMENT REPORT
 WOOLWICH BIO-EN FACILITY
 Elmira, Ontario

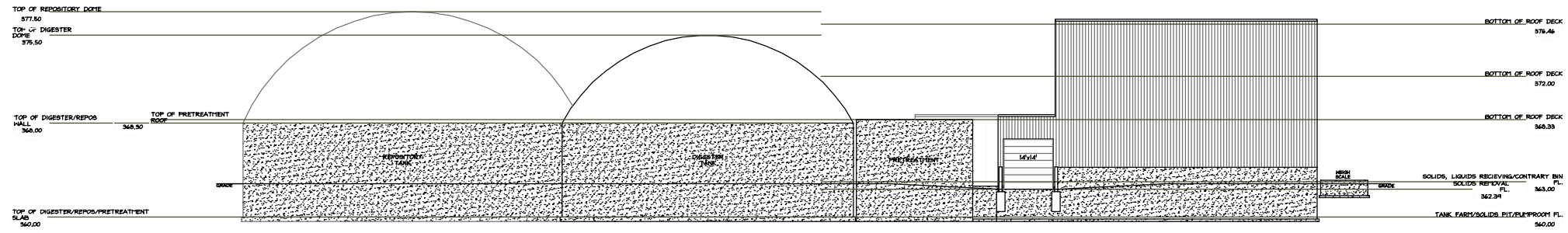

EAST ELEVATION

SCALE = 1:500

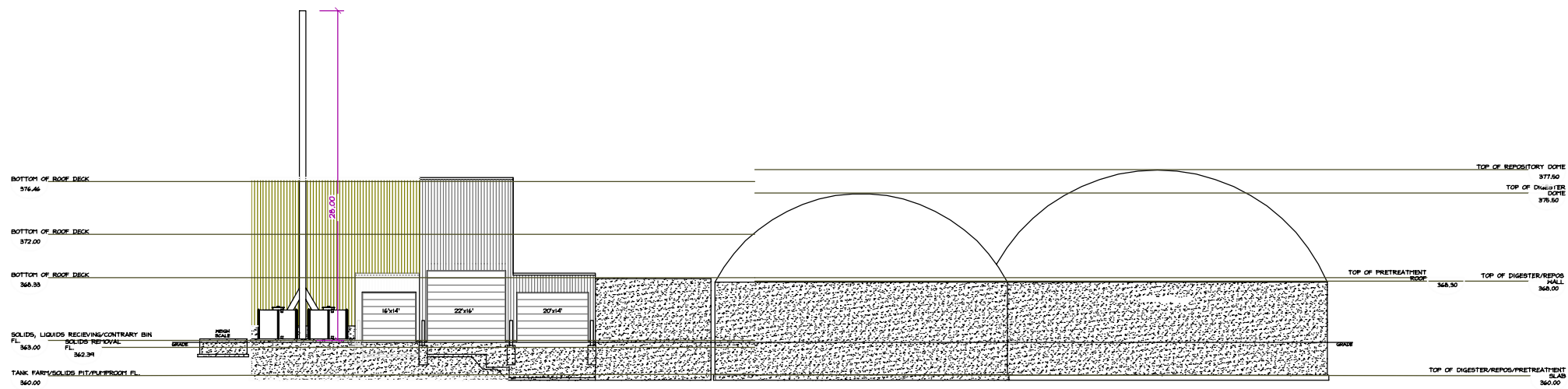

WEST ELEVATION

SCALE = 1:500

figure A.2
 EAST AND WEST BUILDING ELEVATIONS
 ACOUSTIC ASSESSMENT REPORT
 WOOLWICH BIO-EN FACILITY
 Elmira, Ontario



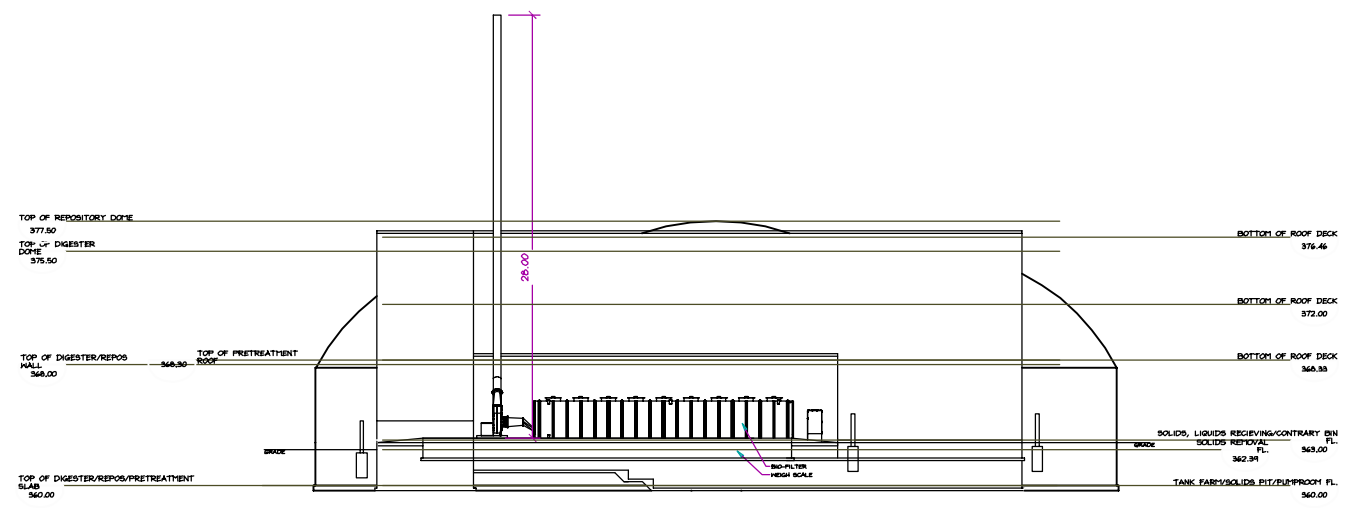

NORTH ELEVATION

SCALE = 1:500

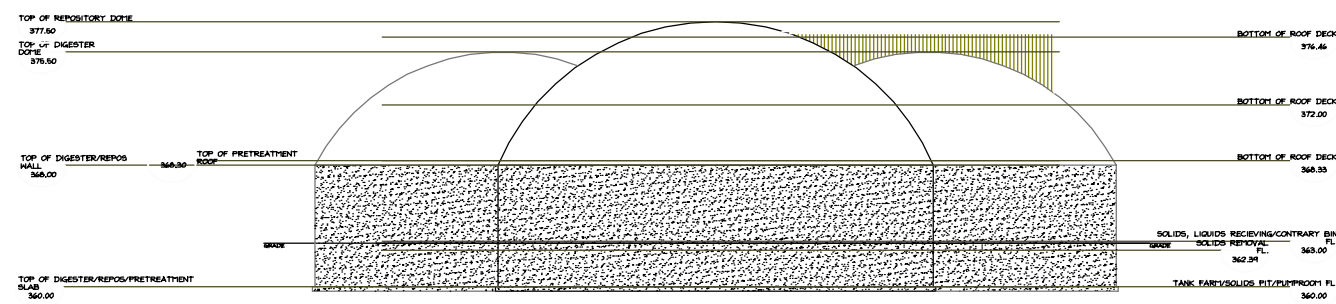

SOUTH ELEVATION

SCALE = 1:500

figure A.3

NORTH AND SOUTH BUILDING ELEVATIONS
 ACOUSTIC ASSESSMENT REPORT
 WOOLWICH BIO-EN FACILITY
 Elmira, Ontario



APPENDIX B

NOISE SPECIFICATION AND WORST-CASE
SIMULTANEOUS OPERATIONS SUMMARY



Engine

Sound pressure level

Aggregate b)		dB(A) re 20 μ Pa	
31,5	Hz	dB	97
63	Hz	dB	79
125	Hz	dB	87
250	Hz	dB	98
500	Hz	dB	95
1000	Hz	dB	91
2000	Hz	dB	86
4000	Hz	dB	88
8000	Hz	dB	92
Exhaust gas a)		dB(A) re 20 μ Pa	89
31,5	Hz	dB	115
63	Hz	dB	95
125	Hz	dB	117
250	Hz	dB	115
500	Hz	dB	113
1000	Hz	dB	108
2000	Hz	dB	105
4000	Hz	dB	108
8000	Hz	dB	109
		dB	107

Sound power level

Aggregate		dB(A) re 1pW	
Measurement surface		m ²	117
Exhaust gas		dB(A) re 1pW	107
Measurement surface		m ²	123
			6.28

a) average sound pressure level on measurement surface in a distance of 1m according to DIN 45635, precision class 2.
 b) average sound pressure level on measurement surface in a distance of 1m (converted to free field) according to DIN 45635, precision class 3.
 Operation with 1200 rpm see upper values, operation with 1800 rpm add 3 dB to upper values.
 Engine tolerance \pm 3 dB

S1A, S1B
Silencer

HVAC Circular Silencer

Model	VPM
Quantity	2

Dimensions	
ID	14 in.
OD	26 in.
L	180 in.

Design Conditions	
Flow	10000 cfm
Static Pressure	n/a WG
Temperature	878 °F
Pressure Drop	2.00 WG

Approx. Weight	1650 lbs.
----------------	-----------

Acoustic Performance								
Frequency (Hz)	63	125	250	500	1000	2000	4000	8000
DIL (dB)	13	20	38	40	40	38	32	26

Construction Notes

- Outer Casing: 11 ga. Fully welded MS construction.
- Inner Liner: 11 ga. Perforated 304 SS.
- Acoustic Media: 3.0 lb./cu.ft. Mineral wool packed under compression.
- Flanges: 14" MS Flanges with ANSI drilling pattern.
- Special Options: Fiberglass Cloth Liner. Stainless Steel Wire Mesh.
- Drain plug. High temperature black paint.

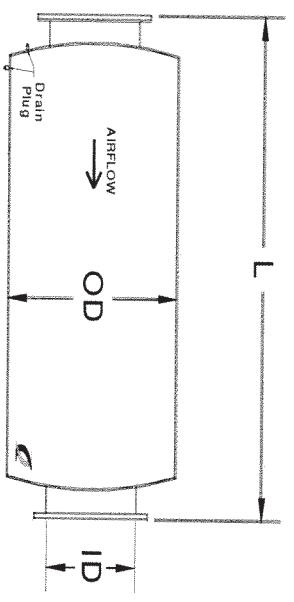

Vendatech Inc.

Tel: (416) 787-8797 Fax: (416) 787-8711

Customer Name: DDA Canada East	
Project Name: BioEn Elmira	
Item Reference: J420 exhaust sil.	Date: January 14, 2010
Dwg. Reference: Proposal	Tolerance is ± 1/8

S2A, S2B



Universal Fan & Blower Ltd.

The Composite Fan Company

P.O. Box 40, 30 Barker's Lane
 Bloomfield, ON, Canada K0K 1G0
 Tel: 613-393-3267
 Fax: 613-393-1937

Date November 11 2009

Proposal

Customer

Tag FAN001

Contact

Project

Customer Ref.

Location

Technical - Submittal Information

Conditions Specified

Volume 5900 cfm
 Inlet Pressure 0.00 inwg (Static)
 Outlet Pressure 10.00 inwg (Static)
 Density 0.075 lb/ft³
 Humidity 40 %
 Operating Temperature 70 °F
 Altitude 0 ft above sea level

Selection Details

Product Code FRBXC-330-9W036
 Volume 5900 cfm
 Pressure @ 0.075 Lb/ft³ 10.00 inwg (Static)
 Pressure @ 0.075 Lb/ft³ 10.00 inwg (Static)
 Power @ 0.075 Lb/ft³ 14.53 HP
 Power @ 0.075 Lb/ft³ 14.53 HP
 Fan Speed / Max Speed 1306 / 1736 rpm
 Wheel Tip Speed 11284 fpm
 Outlet Velocity 2977 fpm
 Static Efficiency 64 %
 Est. Bare Shaft Fan Weight 270 kg

Motor Details (supplied by UFBL)

Frame Size 256T
 Enclosure TEFC
 Type EPACT
 Sync. Speed 1800 rpm
 Power 20 HP
 Supply 460/3/60
 Est. Motor and Drive Weight 165 kg

Fan Part Number

FRBXC-101-FA

Features Specified

1 x DRIVE-226-FT Fixed v-belt drive

Sound Information

Sound Power Levels in dB re. 10⁻¹² Watts:

Sound Spectrum Levels at Inlet							
63	125	250	500	1k	2k	4k	8k
115	108	88	87	83	80	72	64

Overall Sound Power (LwA) 95 dBA
 Estimated overall Sound Pressure (LpA) 82 dBA @ 7 ft

Estimated sound pressure based on free field, hemispherical radiation (Q = 2), at the stated distance

Sound Pressure levels of a fan are affected by the acoustic properties of the surrounding's in which it is installed and consequently dBA levels cannot be guaranteed. Refer to AMCA Publication 303 for further information.

S4 to S13

Repository & Digester Agitators 1-10

Geared motors
Motors

Motors up to size 310

Selection and ordering data

1) point 20% in manual for type of motor

IEC motor size	Integrated motor LA/LG	Order number		Measuring surface sound pressure level		Sound pressure level <i>power</i>	No-load operating	Moment of inertia	Weight
		9th position	10th position	L _{plA}	L _{plB}				
				dB(A)	dB(A)		Z ₀	J _{rot}	m _{rot}
							/h	kgm ²	kg
71	LA71B4	C	B	48	59		20 000	0.00052	5.5
	LA71C4	C	C	48	59		20 000	0.00052	5.5
	LA71S4	C	D	48	59		15 000	0.00052	5.5
	LA71M4	C	E	48	59		15 000	0.00077	6.9
	LA71ZMP4 ¹⁾	C	G	50	61		7 000	0.00110	8.1
	LA71ZMD4 ¹⁾	C	H	50	61		7 000	0.00120	8.6
80	LA80S4 ¹⁾	D	B	51	62		10 000	0.00140	10.4
	LA80M4	D	C	51	62		10 000	0.00170	11.5
90S	LA90S4	E	L	52	64		8 000	0.00240	15.0
90L	LA90L4	E	P	52	64		8 000	0.00330	17.9
	LA90ZLB4 ¹⁾	E	Q	54	66		5 000	0.00400	20.7
100L	LA100L4	F	L	57	69		7 000	0.00470	24.1
	LA100LB4	F	M	57	69		7 000	0.00550	27.6
112M	LA112MB4	G	H	57	69		5 000	0.01200	35.7
132S	LA132SB4	H	F	66	78		3 000	0.01800	47.2
132M	LA132M4	H	H	66	78		3 000	0.02300	56.4
	LA132ZMP4	H	T	68	80		1 600	0.02900	69.0
160M	LA160MB4	J	P	70	82		2 000	0.04300	84.0
160L	LA160L4	J	R	70	82		2 000	0.05500	98.0
180M	LG180ZMB4E	K	L	64	77		800	0.12000	180.0
190L	LG180ZLB4E	K	P	64	77		800	0.14000	210.0
200L	LG200LB4E	L	M	66	79		640	0.23000	260.0
225S	LG225S4E	M	E	64	77		370	0.40000	290.0
225M	LG225ZM4E	M	U	64	77		390	0.49000	330.0
250M	LG250ZM4E	N	N	65	79		230	0.86000	460.0
280S	LG280S4E	P	G	71	84		210	1.40000	575.0
280M	LG290ZM4E	P	W	71	84		150	1.70000	675.0
315S	LG315S4	Q	Q	74	87		160	1.90000	730.0
315M	LG315M4	Q	S	74	87		150	2.30000	810.0
315L	LG315L4	Q	U	74	87		130	2.90000	955.0
	LG315LB4	Q	V	75	80		110	3.50000	955.0

1) Only for integrated motors
2) Only for IEC

Noise

Noise emitted by the motors during mains operation

Noise is measured in accordance with DIN EN ISO 1680 in a dead room. The noise level is specified as A-weighted measuring surface sound pressure level L_{p1A} in dB (A). This value is the spatial average value of the sound pressure levels measured at the measuring surface. The measuring surface is a cube 1 m away from the surface of the motor. The sound power level is also specified as L_{WA} in dB (A).

The values specified in the motor selection tables apply to the motor without gear unit at 50 Hz (see the selection and ordering data in the corresponding sections of the catalog). The tolerance is +3 dB. At 60 Hz, the values are approximately 4 dB (A) higher. Please enquire about noise levels for pole-changing motors, geared motors, and inverter-fed motors.

Noise emitted by the geared motors

The geared motors do not exceed the permissible noise levels defined for gear units in VDI guideline 2159 and for motors in EN 60034. Experience tells us that the geared motors emit a noise that is around 3 - 5 dB (A) louder than that emitted by the motors. Precise data is available on request.

Weight of geared motors

The weight data contained in the dimension drawings are averaged values and do not take account of oil. The weights vary according to the gear unit design and size. The oil quantity depends on the mounting position. You will find oil quantity guide values in the gear unit chapters, "Oil quantities" section. The exact weight of the drive will be specified on the order confirmation.

Three-phase AC motors

Three-phase AC motors are designed to be perfectly coordinated with the gear unit system and can be supplied with or without a brake.

The motor series covers sizes 71 to 315. The powers of the 2-, 4-, 6-, and 8-pole motors are classified in accordance with IEC. Pole-changing designs with pole numbers 8/2; 8/4; 4/2; 6/4 are available on request. The housings of motors up to size 160 are made from high-quality aluminum alloy. Housings for sizes 180 and above are made from gray cast iron.

Brakes

The motors can be supplied with spring-operated disk brakes. These are double-disk brakes, which are spring-operated at zero current.

The torque can be set within certain limits for every brake size.

S14 to S17

Telefon: +49 7522 976959

ARMATEC ▲

03-06-09 15:59 S.: 1/1



Exzentrerschneckenpumpen
Drehkolbenpumpen · Rührwerke
Balgpumpen · Armaturen

+49 7522 976959
BIO-GAS
Ausrüster

Armatec
Streicher

Hydrolysis Agitators Agitator 11-13,17



Armatec FTS-Armaturen GmbH & Co KG
Simoniusstraße 18 und 28 · D-88239 Wangen

Ing. Gerhard Agrinz GmbH
- 3. Juni 2009
Ret. lse

Ing. Gerhard Agrinz GmbH
Engineering & Consulting
Herrn DI Armin Schöllauf
Emmerich-Asemann-Gasse 6

Simoniusstraße 18 und 28
88239 Wangen
Telefon +49(0)75 22/97 69-0
Telefax +49(0)75 22/97 69-59

<http://www.armatec-fts.de>
eMail: info@armatec-fts.de
Ident-Nr.: DE147358673

A- 8430 Leibnitz

Fax Nr. 0043- 3452/ 73997-9

Wangen, den 03.06.2009
Wolfgang Backfisch

Schallmesswerte unserer Langwellenrührwerke

Sehr geehrter Herr Dipl. Ing. Schöllauf,

nachstehend noch die gewünschten Schallmesswerte für unsere Rührwerke:

Messungen im Freien bei einem Abstand von 1,0 m	Ø 72,2 dBA
Messungen im Freien bei einem Abstand von 6,0 m	Ø 66,4 dBA
Messungen im Freien bei einem Abstand von 28,0 m	Ø 45,8 dBA

Die neuen Getriebemotoren die wir seit ca. ½ Jahr einsetzen, haben noch ca. 5-7 % niedere Werte, die wir aber erst veröffentlichen werden, wenn die Versuche abgeschlossen sind.

Mit freundlichen Grüßen

Armatec FTS- Armaturen GmbH & Co. KG

Bank: Volksbank Wangen	Deutsche Bank Wangen	Registergericht Ulm HRA-Nr. 620906
BLZ: 880920 10	BLZ 680 700 24	Persönlich haftende Gesellschaft FTS Armaturen GmbH
Kto. Nr.: 34 019 006	0 925 926	
BIC Code: GENODE31WAN	DEUTDE33650	Registergericht Ulm HRB-Nr. 620300
IBAN-Code: DE24650920100034019006	DE886607002400925926	Geschäftsführer: Jessica Haas-Garlach, Herbert Zirkel

Source 18A/B

Emergency Cooler

Button Stromart Limited

Ring Radiator Services

1.	CUSTOMER: DDACE Toronto		
2.			
3.	JOB REFERENCE:		
4.	ENGINE: JMS420a81		
5.	QUOTE: J09-282		
6.			
7.	COOLING DUTY	HT CIRCUIT	LT CIRCUIT
8.	HEAT REJECTION (MBH)	2718	188
9.	COOLANT TYPE	50% E Glycol	50% E Glycol
10.	COOLANT FLOW (GPM)	364	89
11.	COOLANT PRESSURE DROP (PSI)	4.7	2.2
12.	TEMPERATURE IN (F)	175	135.9
13.	TEMPERATURE OUT (F)	157.8	131
14.	DESIGN AMBIENT TEMPERATURE (F)	104°F	
15.	DESIGN ELEVATION (FT ASL)	656'	
16.	EXTERNAL STATIC (" WG)	0	
17.			
18.	FAN(S) – NUMBER / DIAMETER	(8) 30"	
19.	MOTOR(S) – NUMBER / HP	(8) 1.5	
20.	MOTOR PHASE / HERTZ / VOLTAGE	575/3/60	
21.	AIRFLOW (SCFM)	54000	
22.	NOISE LEVEL (DBA @ DISTANCE)	66 DBA @ 10 meters all fans operating full speed. ←	
23.	RADIATOR MODEL	SMVE-0809252	
24.	OVERALL DIMENSIONS (INCHES)	82" Wide, 183" Long, 84" Minimum Height.	
25.	ESTIMATED DRY WEIGHT (LBS)	TBA	
26.	ESTIMATED LIQUID VOLUME (GAL)	TBA	
27.	RADIATOR PRICE:		
28.	FOB POINT: Sutton Stromart, Brampton, Ontario		
29.	LEADTIME: From receipt of order drawings for approval within 2 – 3 weeks. From receipt of release 12-14 weeks ready to ship.		
30.	COMMENTS: Radiator includes a radiator mounted electrical panel with motor overloads on all motors and half will have contactors for on off operation, remaining four for operation on VFD. This can be changed accordingly if needed.		
31.	COMMENTS: Price includes radiator mounted expansion tanks with 0.9 BarG industrial radiator caps, Murphy switches and sight glasses.		
32.	COMMENTS: Radiator will be fabricated of galvanized sheet steel panels and hot dipped galvanized steel structures. Add for air dried epoxy after assembly \$2625.00.		
33.	PREPARED BY: Jim Ikola		
34.	DATE: June 8, 2009		

Sources S19A/B & S20A/B

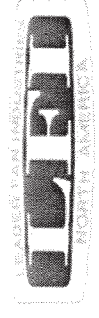

DDS: Direct Drive Wall Fans

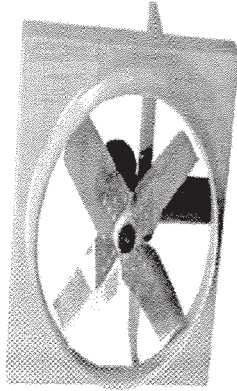

- Heavy gauge steel fan panel with deep spun and flared venturi for maximum efficiency.
- Heavy gauge, welded steel motor support.
- Heavy duty galvanized steel blades.
- TEFC motors are standard.
- Available accessories include cabinets, sleeves, guards, back draft dampers, control dampers, louvers and weather hoods.

Model DDS: Direct Drive Fans

Leader Fan Number		Blade Dia.	RPM	H.P.	CFM @ Static Pressure							dBA @ 5 Ft.
Single Phase	Three Phase				0"	1/8"	1/4"	3/8"	1/2"	5/8"	3/4"	
DDS12T1025C	DDS12T3025C*	12"	1140	1/4	940	647	325	697	587	419	234	53
DDS12T1033B	DDS12T3033B*	12"	1750	1/3	1422	1285	1062	697	587	419	234	65
DDS14T1025C	DDS14T3025C*	14"	1140	1/4	1346	1082	624	395	111	1032	733	58
DDS14T1033B	DDS14T3033B*	14"	1750	1/3	2037	1879	1705	1417	1032	733	733	67
DDS16T1025C	DDS16T3025C*	16"	1140	1/4	1931	1660	1067	705	463	133	1314	63
DDS16T1033B	DDS16T3033B*	16"	1750	1/3	2928	2841	2607	2223	1808	1521	1314	72
DDS18T1025C	DDS18T3025C*	18"	1140	1/4	2654	2331	1606	1077	745	449	228	64
DDS18T1033B	DDS18T3033B*	18"	1750	1/2	4016	3816	3594	3304	2934	2173	1814	74
DDS20T1025C	DDS20T3025C*	20"	1140	1/3	3561	3210	2734	1774	1350	986	675	69
DDS20T1033B	DDS20T3033B*	20"	1750	1	5389	5162	4926	4674	4350	3951	3191	78
DDS24T1075C	DDS24T3075C*	24"	1140	3/4	6349	6017	5527	4482	3454	2801	2376	73
DDS24T1100B	DDS24T3100B*	24"	1750	1	6761	6453	6128	5792	5291	4802	4316	81
DDS24T1300B	DDS24T3300B*	24"	1750	3	9909	9558	9207	8886	8599	8131	7576	84
DDS30T1500B	DDS30T3150C*	30"	1140	1.5	11600	10925	10193	9127	7504	6177	5178	79
	DDS30T3300B*	30"	1750	5	17552	17106	16681	16215	15745	15190	14541	90
	DDS36T3500C*	36"	860	2	16364	15172	13864	11597	9443	8094	6134	80
	DDS36T3500C*	36"	1140	5	21092	20793	19893	18903	17883	15993	13983	88
	DDS42T3500L*	42"	860	3	24499	23193	21957	20490	18000	15890	12704	85
	DDS42T3500C*	42"	1140	5	32209	32619	21962	21019	19925	18829	17519	88
	DDS48T3750L*	48"	860	7.5	35054	34411	31857	30219	28021	25622	22628	89
	DDS48T3750C*	48"	1140	7.5	32563	31677	30688	29636	28562	27222	25793	92

For three phase motors substitute "M" with "C" for 208/230/460 volt or "P" for 575 volt. Fan blades tested in accordance with AMCA standard 216, figure 12. dBA ratings shown are measured at 0" static pressure, and should be used as a guideline only.



Sources 19A/B

HVAC Rectangular Silencer

Model	VCR-22
Quantity	4

Dimensions	
W	47 in.
H	45 in.
L	96 in.

Design Conditions	
Flow	11,875 cfm
Static Pressure	n/a WG
Temperature	100 °F
Pressure Drop	0.15 WG

Approx. Weight	800 lbs.
----------------	----------

Acoustic Performance*								
Frequency (Hz)	63	125	250	500	1000	2000	4000	8000
DIL (dB)	9	15	23	32	39	32	24	20

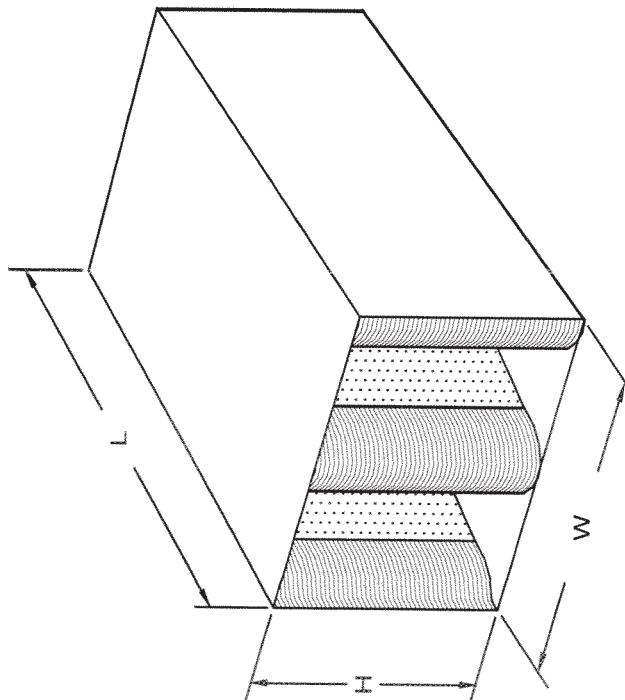

Construction Notes

- Outer Casing: 16 ga. galvanized steel.
- Inner Liner: 22 ga. perforated galvanized steel
- Acoustic Media: 3.0 lb/cu.ft. mineral wool packed under compression
- Flanges: 1" Slip flanges on both ends.
- Special Options: HTL, Fiberglass Cloth Liner.
- Union Status: Non-union



Vendatech Inc.

Tel.: (416) 787-8797 Fax: (416) 787-8711

Customer Name:	DDAce Power Systems		
Project Name:	BioEn		
Item Reference:	Discharge	Date:	January 11, 2010
Dwg. Reference:	Proposal	Tolerance is ± 1/8	

* Rated performance is per ASTM E477-96 testing methods.

Sources 20A/B

HVAC Rectangular Silencer

Model	VCR-22
Quantity	4

Dimensions	
W	47 in.
H	45 in.
L	96 in.

Design Conditions	
Flow	-12,500 cfm
Static Pressure	n/a WG
Temperature	75 °F
Pressure Drop	0.15 WG

Approx. Weight	800 lbs.
----------------	----------

Acoustic Performance*								
Frequency (Hz)	63	125	250	500	1000	2000	4000	8000
DIL (dB)	10	16	24	33	39	31	23	19

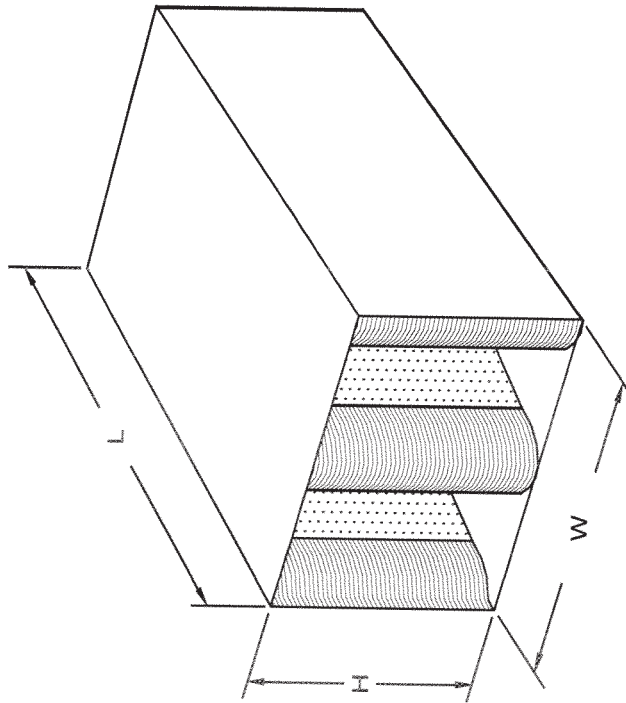

Construction Notes

- Outer Casing: 16 ga. galvanized steel.
- Inner Liner: 22 ga. perforated galvanized steel
- Acoustic Media: 3.0 lb/cu.ft. mineral wool packed under compression
- Flanges: 1" Slip flanges on both ends.
- Special Options: HTL, Fiberglass Cloth Liner.
- Union Status: Non-union



Vendatech Inc.

Tel.: (416) 787-8797 Fax: (416) 787-8711

Customer Name:	DDAce Power Systems		
Project Name:	BioEn		
Item Reference:	Intake	Date:	January 11, 2010
Dwg. Reference:	Proposal	Tolerance is ± 1/8	

* Rated performance is per ASTM E477-96 testing methods.

TYPE **OMM/PROV. ONF - 3 PHASE PADMOUNT** kVA **4000/PR.5333** H.V. **27600 DELTA** BIL **150 KV** L.V. **600Y/347** BIL **30 KV** TEMP. RISE **65°C** FREQ. **60 Hz.** TAPS. **4-2.1/2% (2FCAN,2FCBN)** MASS **9790 kg.** OIL **3075 L.**

- 1- NON-REMOVABLE COOLING RADIATORS
- 2- BOLTED COVER C/W TAMPERPROOF FLANGES
- 3- TAMPERPROOF CABINET DOOR C/W GROUNDING, PROVISION FOR PADLOCKING AND 2 ~ 1/2"-13 PENTAHEAD BOLTS C/W FIX CUPWASHERS
- 4- TRANSFORMER LIFTING LUGS
- 5- TOP FILTER-PRESS LUGS
- 6- PRESSURE RELIEF VALVE ~ 1" NPT C/W BRASS PLUG
- 7- EXTERNALLY OPERATED TAP SWITCH HANDLE C/W WARNING DECAL
- 8- AL. NAMEPLATE C/W CONNECTION DIAGRAM
- 9- H.V. BUSHINGS C/W PAD 2 HOLES 9/16" NEMA DRILLING
- 10- L.V. BUSHINGS ~ EPOXY TYPE TIN PLATED C/W 8 HOLES SPADE
- 11- L.V. STAINLESS STEEL BUSHING PLATE (NOT SHOWN)
- 12- X0 S.S. GROUND PAD C/W REMOVABLE STRAPS
- 13- S.S. GROUND PAD
- 14- WARNING LABELS AS PER EEMAC L16-1 ON THE INSIDE & OUTSIDE OF CABINET DOOR
- 15- L.V. THROAT (SEE DETAIL) C/W TAMPERPROOF TOP HANDHOLE (OP.: 762 X 203)
- 16- BRONZE BALL DRAIN VALVE 1" NPT C/W SAMPLING DEVICE
- 17- LIQUID TEMPERATURE GAUGE ~ QUALITROL No. 167-278-01 C/W 2 CONTACTS
- 18- LIQUID LEVEL GAUGE ~ QUALITROL No. 020-031-01
- 19- EXTERNAL STIFFENERS
- 20- 3/8"-16 X 1 1/8" LG. ~ 17 S.S. STUDS
- 21- MOUNTING PLATE FOR FUTURE FAN CONTROL
- 22- FANS, NOT TAMPERPROOF 24", DIA. 120V, 1 PH., (PROVISION ONLY)
- 23- TAMPERPROOF COVER (USE AT PIONEER FOR VACUUM FILLING)

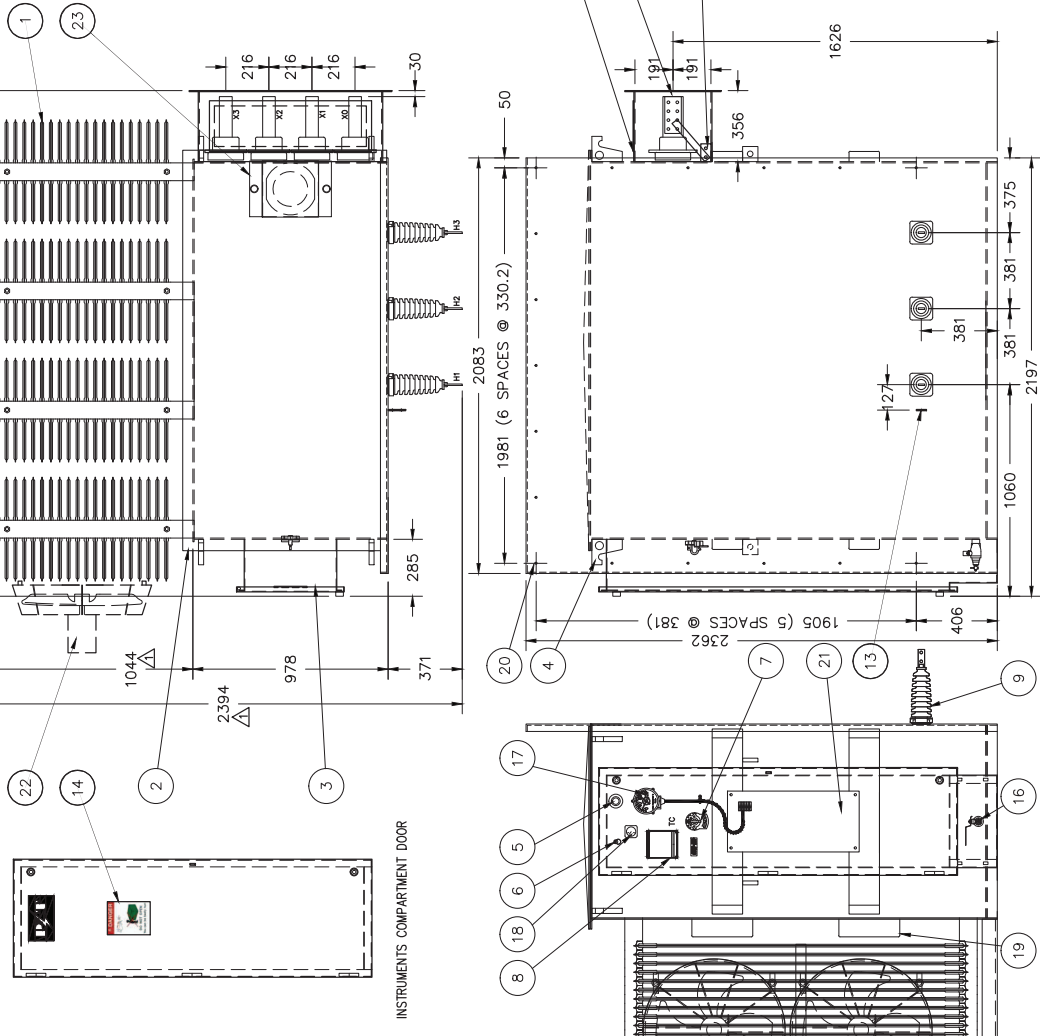

NOTES:
 PAINTED FINISH ~ GREY ANSI 70
 TRANSFORMER BUILT TO CUSTOMER'S SPECIFICATION
 ALL DIMENSIONS IN MILLIMETER
 ENERGY EFFICIENCY PER CAN/CSA C802.1-00

△ DIMENSION 1094 WAS 1000 & 2394 WAS 2349, REVISED TOTAL MASS & QUANTITY OF LIQUID. SEP-05-09. P.L.

PBW HIGH VOLTAGE LTD. CABLE IN WATER/OIL	09-91DC68	1	01-079-128	G15474-1	QUANTITIES IN BRACKET
CUSTOMER	CUST. PRODUCT CODE	PURCH. ORDER NO.	ITEM	QUOTATION No.	SERIAL No.
ADDITIONS TO THE ABOVE TABLE WILL NOT AFFECT THE REVISION NUMBER OF THIS DRAWING.					
TITLE					
TRANSFORMER OUTLINE					
PADMOUNT FLAT FACE TYPE					
TOLERANCES UNLESS OTHERWISE SPECIFIED					
TOL. ±12mm					
SCALE 1 = 22					
DRAWN P.L. DATE AUG-19-09					
CHECKED P.L. DATE 4/15-19-09					
APP. AT DATE 4/15-19-09					
DWG. NO.				REV.	
G1103B7453				1	



TABLE B.1
NOISE SPECIFICATIONS SUMMARY
WOOLWICH BIO-EN INC.
ELMIRA, ONTARIO

Cadna ID	Noise Source Description		1/1 Octave Band Data									HAG (m)	Reference Distance (m)
			31.5	63	125	250	500	1K	2K	4K	8K		
S1A & S1B	Engines (Exhaust)	Pressure Level (dB)	95.0	117.0	115.0	113.0	108.0	105.0	108.0	109.0	107.0	9.55	1.0
S1A & S1B	Engines (Exhaust Silencers)	DIL (dB)	-	13	20	38	40	40	38	32	26	-	-
S2A & S2B	Biofilter Fan #1 & #2	Power Level (dB)	-	115.0	108.0	88.0	87.0	83.0	80.0	72.0	64.0	2	-
S4-S13	Agitators 1-10	Power Level (dBA)	-	-	-	-	82.0	-	-	-	-	7.0	-
S14-S17	Agitators 11-13, 17	Pressure Level (dBA)	-	-	-	-	66.4	-	-	-	-	5.78	6.0
S18A & S18B	Radiators	Pressure Level (dBA)	-	-	-	-	66.0	-	-	-	-	2	10.0
S19A & S19B	Engine Room Discharges	Pressure Level (dBA)	-	-	-	-	88.0	-	-	-	-	2.5	1.5
S19A & S19B	Engine Room Discharges (Silencer)	DIL (dB)	-	9.0	15.0	23.0	32.0	39.0	32.0	24.0	20.0	-	-
S20A & S20B	Engine Room Intakes	Pressure Level (dBA)	-	-	-	-	88.0	-	-	-	-	6.55	1.5
S20A & S20B	Engine Room Intakes (Silencer)	DIL (dB)	-	10.0	16.0	24.0	33.0	39.0	31.0	23.0	19.0	-	-
S21	Transformer	Power Level (dBA)	32.6	51.8	63.9	66.4	71.8	69.0	65.2	60.0	50.9	2.4	see TB.2
T1	Truck Route (1)	Pressure Level (dBA)	-	-	-	-	75.0	-	-	-	-	2	15.0

Notes:

HAG - Height above grade

(1) Truck Route hourly movements =20 (day) and 2 (night), speed = 10 km/hr

TABLE B.2

TRANSFORMER SOUND POWER LEVEL CALCULATIONS
 WOOLWICH BIO-EN INC.
 ELMIRA, ONTARIO

Transformer Data - T1

Length	2.53 m
Width	2.36 m
Height	2.08 m

Measured or Manufacturer Tested Sound Pressure Level (dBA) (1)	60.80
Transformer Surface Area (inclusive of fan banks) (m ²) (2)	26
Transformer Calculated Sound Power Rating (dBA) (3)	75.0

Octave Band (Hz)	32	63	125	250	500	1000	2000	4000	8000	
Correction Factor (4)	-3	3	5	0	0	-6	-11	-16	-23	Total
Sound Power Level (dB)	72	78	80	75	75	69	64	59	52	84.1
A-weighting	-39.4	-26.2	-16.1	-8.6	-3.2	0.0	1.2	1.0	-1.1	
Sound Power Level (dBA)	32.6	51.8	63.9	66.4	71.8	69.0	65.2	60.0	50.9	75.4

Notes:

- (1) Manufacturer tested sound level.
- (2) The following transformer surface area calculation based on 5 exposed sides as provided by Pioneer Transformers.
 $= (2 * (2.533 * 2.083)) + (2 * (2.362 * 2.083)) + (2.533 * 2.362)$
- (3) Calculated as per IEEE C57.12.90-2006, "IEEE Standard Test Code for Liquid-Immersed Distribution, Power, and Regulating Transformers."
- (4) Octave band correction factors obtained from Table 1 of the Encyclopedia of Acoustics, 1997, Chapter 86 - "Sound Power Level Predictions for Industrial Machinery".

APPENDIX C

INSIGNIFICANT NOISE SUMMARY TABLE

TABLE C.1
INSIGNIFICANT NOISE SOURCE SUMMARY
WOOLWICH BIO-EN INC.
ELMIRA, ONTARIO

<i>C of A</i> <i>ID</i>	<i>Source Description</i>	<i>Comments</i>
S3	Flare (1)	Insignificant noise source based on manufacturers specifications.
S21	Transformer	Insignificant noise source based on modelling
S22	Start-Up Boiler	Insignificant noise source based on modelling (S4 in ESDM)
NA	Fork Trucks	Insignificant noise source - operated indoors
NA	Pumps/pneumatic devices	Insignificant noise source.
NA	Truck loading/unloading	Insignificant noise source - completed indoors or pumps are indoors

Note:

(1) Based on discussions with manufacturer, flare has insignificant noise as the gas pressure is only about 3.25 inches WC (about as noisy as a BBQ flame).

APPENDIX D

CADNA A MODEL OUTPUT FILE AND CD

Configuration	
Parameter	Value
General	
Country	(user defined)
Max. Error (dB)	0.00
Max. Search Radius (m)	2000.00
Min. Dist Src to Rcvr	0.00
Partition	
Raster Factor	0.50
Max. Length of Section (m)	1000.00
Min. Length of Section (m)	1.00
Min. Length of Section (%)	0.00
Proj. Line Sources	On
Proj. Area Sources	On
Ref. Time	
Reference Time Day (min)	960.00
Reference Time Night (min)	480.00
Daytime Penalty (dB)	0.00
Recr. Time Penalty (dB)	0.00
Night-time Penalty (dB)	0.00
DTM	
Standard Height (m)	348.00
Model of Terrain	Triangulation
Reflection	
max. Order of Reflection	1
Search Radius Src	100.00
Search Radius Rcvr	100.00
Max. Distance Source - Rcvr	1000.00 1000.00
Min. Distance Rcvr - Reflector	1.00 1.00
Min. Distance Source - Reflector	0.10
Industrial (ISO 9613)	
Lateral Diffraction	some Obj
Obst. within Area Src do not shield	On
Screening	
	Excl. Ground Att. over Barrier
	Dz with limit (20/25)
Barrier Coefficients C1,2,3	3.0 20.0 0.0
Temperature (°C)	10
rel. Humidity (%)	70
Ground Absorption G	0.00
Wind Speed for Dir. (m/s)	3.0
Roads (???)	
Railways (???)	
Aircraft (???)	
Strictly acc. to AzB	

Point Source, ISO 9613, Name: "Biofilter fan", ID: "S2B"																			
Nr.	X	Y	Z	Refl.	Freq.	LxT	LxN	K0	Dc	Adiv	Aatm	Agr	Afol	Ahous	Abar	Cmet	RL	LrT	LrN
	(m)	(m)	(m)		(Hz)	dB(A)	dB(A)	(dB)	(dB)	(dB)	(dB)	(dB)	(dB)	(dB)	(dB)	(dB)	(dB)	dB(A)	dB(A)
6	536373.92	4828028.71	365.66	0	1000	83.0	83.0	0.0	0.0	59.9	1.0	-1.7	0.0	0.0	20.1	0.0	-0.0	3.6	3.6
7	536373.92	4828028.71	365.66	0	2000	81.2	81.2	0.0	0.0	59.9	2.7	-1.7	0.0	0.0	21.9	0.0	-0.0	-1.7	-1.7
8	536373.92	4828028.71	365.66	0	4000	73.0	73.0	0.0	0.0	59.9	9.2	-1.7	0.0	0.0	23.2	0.0	-0.0	-17.7	-17.7
9	536373.92	4828028.71	365.66	0	8000	62.9	62.9	0.0	0.0	59.9	32.7	-1.7	0.0	0.0	24.0	0.0	-0.0	-52.1	-52.1
10	536373.92	4828028.71	365.66	1	32	-39.4	-39.4	0.0	0.0	60.0	0.0	-3.9	0.0	0.0	8.4	0.0	1.0	-104.9	-104.9
11	536373.92	4828028.71	365.66	1	63	88.8	88.8	0.0	0.0	60.0	0.0	-3.9	0.0	0.0	10.4	0.0	1.0	21.3	21.3
12	536373.92	4828028.71	365.66	1	125	91.9	91.9	0.0	0.0	60.0	0.1	1.4	0.0	0.0	11.7	0.0	1.0	17.7	17.7
13	536373.92	4828028.71	365.66	1	250	79.4	79.4	0.0	0.0	60.0	0.3	-0.3	0.0	0.0	16.9	0.0	1.0	1.5	1.5
14	536373.92	4828028.71	365.66	1	500	83.8	83.8	0.0	0.0	60.0	0.5	-1.7	0.0	0.0	21.2	0.0	1.0	2.7	2.7
15	536373.92	4828028.71	365.66	1	1000	83.0	83.0	0.0	0.0	60.0	1.0	-1.7	0.0	0.0	25.0	0.0	1.0	-2.4	-2.4
16	536373.92	4828028.71	365.66	1	2000	81.2	81.2	0.0	0.0	60.0	2.7	-1.7	0.0	0.0	25.0	0.0	1.0	-5.9	-5.9
17	536373.92	4828028.71	365.66	1	4000	73.0	73.0	0.0	0.0	60.0	9.3	-1.7	0.0	0.0	25.0	0.0	1.0	-20.6	-20.6
18	536373.92	4828028.71	365.66	1	8000	62.9	62.9	0.0	0.0	60.0	33.0	-1.7	0.0	0.0	25.0	0.0	1.0	-54.4	-54.4

Point Source, ISO 9613, Name: "Agitator 1", ID: "S4"																			
Nr.	X	Y	Z	Refl.	Freq.	LxT	LxN	K0	Dc	Adiv	Aatm	Agr	Afol	Ahous	Abar	Cmet	RL	LrT	LrN
	(m)	(m)	(m)		(Hz)	dB(A)	dB(A)	(dB)	(dB)	(dB)	(dB)	(dB)	(dB)	(dB)	(dB)	(dB)	(dB)	dB(A)	dB(A)
1	536331.65	4828009.55	369.56	0	500	82.0	82.0	0.0	0.0	58.7	0.5	-0.3	0.0	0.0	9.1	0.0	-0.0	14.0	14.0

Point Source, ISO 9613, Name: "Agitator 2", ID: "S5"																			
Nr.	X	Y	Z	Refl.	Freq.	LxT	LxN	K0	Dc	Adiv	Aatm	Agr	Afol	Ahous	Abar	Cmet	RL	LrT	LrN
	(m)	(m)	(m)		(Hz)	dB(A)	dB(A)	(dB)	(dB)	(dB)	(dB)	(dB)	(dB)	(dB)	(dB)	(dB)	(dB)	dB(A)	dB(A)
1	536312.63	4827995.86	368.92	0	500	82.0	82.0	0.0	0.0	58.2	0.4	-0.2	0.0	0.0	0.0	0.0	-0.0	23.5	23.5

Point Source, ISO 9613, Name: "Agitator 3", ID: "S6"																			
Nr.	X	Y	Z	Refl.	Freq.	LxT	LxN	K0	Dc	Adiv	Aatm	Agr	Afol	Ahous	Abar	Cmet	RL	LrT	LrN
	(m)	(m)	(m)		(Hz)	dB(A)	dB(A)	(dB)	(dB)	(dB)	(dB)	(dB)	(dB)	(dB)	(dB)	(dB)	(dB)	dB(A)	dB(A)
1	536332.71	4827992.63	369.53	0	500	82.0	82.0	0.0	0.0	58.9	0.5	-0.3	0.0	0.0	0.0	0.0	-0.0	22.9	22.9

Point Source, ISO 9613, Name: "Agitator 4", ID: "S7"																			
Nr.	X	Y	Z	Refl.	Freq.	LxT	LxN	K0	Dc	Adiv	Aatm	Agr	Afol	Ahous	Abar	Cmet	RL	LrT	LrN
	(m)	(m)	(m)		(Hz)	dB(A)	dB(A)	(dB)	(dB)	(dB)	(dB)	(dB)	(dB)	(dB)	(dB)	(dB)	(dB)	dB(A)	dB(A)
1	536342.47	4827997.19	369.23	0	500	82.0	82.0	0.0	0.0	59.2	0.5	-0.4	0.0	0.0	16.3	0.0	-0.0	6.4	6.4

Point Source, ISO 9613, Name: "Agitator 5", ID: "S8"																			
Nr.	X	Y	Z	Refl.	Freq.	LxT	LxN	K0	Dc	Adiv	Aatm	Agr	Afol	Ahous	Abar	Cmet	RL	LrT	LrN
	(m)	(m)	(m)		(Hz)	dB(A)	dB(A)	(dB)	(dB)	(dB)	(dB)	(dB)	(dB)	(dB)	(dB)	(dB)	(dB)	dB(A)	dB(A)
1	536360.09	4827985.34	369.74	0	500	82.0	82.0	0.0	0.0	59.8	0.5	-0.5	0.0	0.0	19.8	0.0	-0.0	2.3	2.3

Point Source, ISO 9613, Name: "Agitator 6", ID: "S9"																			
Nr.	X	Y	Z	Refl.	Freq.	LxT	LxN	K0	Dc	Adiv	Aatm	Agr	Afol	Ahous	Abar	Cmet	RL	LrT	LrN
	(m)	(m)	(m)		(Hz)	dB(A)	dB(A)	(dB)	(dB)	(dB)	(dB)	(dB)	(dB)	(dB)	(dB)	(dB)	(dB)	dB(A)	dB(A)
1	536342.19	4827976.06	369.87	0	500	82.0	82.0	0.0	0.0	59.4	0.5	-0.4	0.0	0.0	11.0	0.0	-0.0	11.5	11.5

Point Source, ISO 9613, Name: "Agitator 7", ID: "S10"																			
Nr.	X	Y	Z	Refl.	Freq.	LxT	LxN	K0	Dc	Adiv	Aatm	Agr	Afol	Ahous	Abar	Cmet	RL	LrT	LrN
	(m)	(m)	(m)		(Hz)	dB(A)	dB(A)	(dB)	(dB)	(dB)	(dB)	(dB)	(dB)	(dB)	(dB)	(dB)	(dB)	dB(A)	dB(A)
1	536327.57	4827985.16	368.45	0	500	82.0	82.0	0.0	0.0	58.8	0.5	-0.3	0.0	0.0	0.0	0.0	-0.0	23.0	23.0

Point Source, ISO 9613, Name: "Agitator 8", ID: "S11"																			
Nr.	X	Y	Z	Refl.	Freq.	LxT	LxN	K0	Dc	Adiv	Aatm	Agr	Afol	Ahous	Abar	Cmet	RL	LrT	LrN
	(m)	(m)	(m)		(Hz)	dB(A)	dB(A)	(dB)	(dB)	(dB)	(dB)	(dB)	(dB)	(dB)	(dB)	(dB)	(dB)	dB(A)	dB(A)
1	536336.44	4827966.69	368.58	0	500	82.0	82.0	0.0	0.0	59.3	0.5	-0.4	0.0	0.0	19.5	0.0	-0.0	3.0	3.0

Point Source, ISO 9613, Name: "Agitator 9", ID: "S12"																			
Nr.	X	Y	Z	Refl.	Freq.	LxT	LxN	K0	Dc	Adiv	Aatm	Agr	Afol	Ahous	Abar	Cmet	RL	LrT	LrN
	(m)	(m)	(m)		(Hz)	dB(A)	dB(A)	(dB)	(dB)	(dB)	(dB)	(dB)	(dB)	(dB)	(dB)	(dB)	(dB)	dB(A)	dB(A)
1	536317.58	4827959.11	367.79	0	500	82.0	82.0	0.0	0.0	58.9	0.5	-0.3	0.0	0.0	4.7	0.0	-0.0	18.2	18.2

Point Source, ISO 9613, Name: "Agitator 10", ID: "S13"																			
Nr.	X	Y	Z	Refl.	Freq.	LxT	LxN	K0	Dc	Adiv	Aatm	Agr	Afol	Ahous	Abar	Cmet	RL	LrT	LrN
	(m)	(m)	(m)		(Hz)	dB(A)	dB(A)	(dB)	(dB)	(dB)	(dB)	(dB)	(dB)	(dB)	(dB)	(dB)	(dB)	dB(A)	dB(A)
1	536311.13	4827978.47	368.65	0	500	82.0	82.0	0.0	0.0	58.4	0.5	-0.2	0.0	0.0	0.0	0.0	-0.0	23.4	23.4

Point Source, ISO 9613, Name: "Agitator 11", ID: "S14"																			
Nr.	X	Y	Z	Refl.	Freq.	LxT	LxN	K0	Dc	Adiv	Aatm	Agr	Afol	Ahous	Abar	Cmet	RL	LrT	LrN
	(m)	(m)	(m)		(Hz)	dB(A)	dB(A)	(dB)	(dB)	(dB)	(dB)	(dB)	(dB)	(dB)	(dB)	(dB)	(dB)	dB(A)	dB(A)
1	536327.35	4828019.36	368.87	0	500	93.0	93.0	0.0	0.0	58.5	0.5	-0.3	0.0	0.0	0.0	0.0	-0.0	34.3	34.3

Point Source, ISO 9613, Name: "Agitator 12", ID: "S15"																			
Nr.	X	Y	Z	Refl.	Freq.	LxT	LxN	K0	Dc	Adiv	Aatm	Agr	Afol	Ahous	Abar	Cmet	RL	LrT	LrN
	(m)	(m)	(m)		(Hz)	dB(A)	dB(A)	(dB)	(dB)	(dB)	(dB)	(dB)	(dB)	(dB)	(dB)	(dB)	(dB)	dB(A)	dB(A)
1	536339.00	4828012.25	368.94	0	500	93.0	93.0	0.0	0.0	58.9	0.5	-0.4	0.0	0.0	2.1	0.0	-0.0	31.9	31.9
2	536339.00	4828012.25	368.94	1	500	93.0	93.0	0.0	0.0	58.9	0.5	-0.4	0.0	0.0	4.8	0.0	1.0	28.2	28.2

Point Source, ISO 9613, Name: "Agitator 13", ID: "S16"																			
Nr.	X	Y	Z	Refl.	Freq.	LxT	LxN	K0	Dc	Adiv	Aatm	Agr	Afol	Ahous	Abar	Cmet	RL	LrT	LrN
	(m)	(m)	(m)		(Hz)	dB(A)	dB(A)	(dB)	(dB)	(dB)	(dB)	(dB)	(dB)	(dB)	(dB)	(dB)	(dB)	dB(A)	dB(A)
1	536350.13	4828005.98	369.22	0	500	93.0	93.0	0.0	0.0	59.3	0.5	-0.5	0.0	0.0	4.3	0.0	-0.0	29.2	29.2

Point Source, ISO 9613, Name: "Agitator 17", ID: "S17"																			
Nr.	X	Y	Z	Refl.	Freq.	LxT	LxN	K0	Dc	Adiv	Aatm	Agr	Afol	Ahous	Abar	Cmet	RL	LrT	LrN
	(m)	(m)	(m)		(Hz)	dB(A)	dB(A)	(dB)	(dB)	(dB)	(dB)	(dB)	(dB)	(dB)	(dB)	(dB)	(dB)	dB(A)	dB(A)
1	536351.78	4828004.07	369.22	0	500	93.0	93.0	0.0	0.0	59.4	0.5	-0.4	0.0	0.0	16.7	0.0	-0.0	16.8	16.8
2	536351.78	4828004.07	369.22	1	500	93.0	93.0	0.0	0.0	59.4	0.5	-0.4	0.0	0.0	4.8	0.0	1.0	27.7	27.7

Point Source, ISO 9613, Name: "Radiator", ID: "S18A"																			
Nr.	X	Y	Z	Refl.	Freq.	LxT	LxN	K0	Dc	Adiv	Aatm	Agr	Afol	Ahous	Abar	Cmet	RL	LrT	LrN
	(m)	(m)	(m)		(Hz)	dB(A)	dB(A)	(dB)	(dB)	(dB)	(dB)	(dB)	(dB)	(dB)	(dB)	(dB)	(dB)	dB(A)	dB(A)
1	536418.39	4828045.06	365.00	0	500	97.0	97.0	0.0	0.0	61.2	0.6	-2.0	0.0	0.0	4.8	0.0	-0.0	32.4	32.4

Point Source, ISO 9613, Name: "Radiator", ID: "S18B"																			
Nr.	X	Y	Z	Refl.	Freq.	LxT	LxN	K0	Dc	Adiv	Aatm	Agr	Afol	Ahous	Abar	Cmet	RL	LrT	LrN
	(m)	(m)	(m)		(Hz)	dB(A)	dB(A)	(dB)	(dB)	(dB)	(dB)	(dB)	(dB)	(dB)	(dB)	(dB)	(dB)	dB(A)	dB(A)
1	536424.61	4828044.37	365.00	0	500	97.0	97.0	0.0	0.0	61.3	0.6	-2.1	0.0	0.0	4.8	0.0	-0.0	32.3	32.3

Point Source, ISO 9613, Name: "Discharge", ID: "S19A"																			
Nr.	X	Y	Z	Refl.	Freq.	LxT	LxN	K0	Dc	Adiv	Aatm	Agr	Afol	Ahous	Abar	Cmet	RL	LrT	LrN
	(m)	(m)	(m)		(Hz)	dB(A)	dB(A)	(dB)	(dB)	(dB)	(dB)	(dB)	(dB)	(dB)	(dB)	(dB)	(dB)	dB(A)	dB(A)
1	536418.68	4828042.44	365.50	0	500	70.6	70.6	0.0	0.0	61.2	0.6	-1.9	0.0	0.0	5.0	0.0	-0.0	5.7	5.7

Point Source, ISO 9613, Name: "Discharge", ID: "S19B"																			
Nr.	X	Y	Z	Refl.	Freq.	LxT	LxN	K0	Dc	Adiv	Aatm	Agr	Afol	Ahous	Abar	Cmet	RL	LrT	LrN
	(m)	(m)	(m)		(Hz)	dB(A)	dB(A)	(dB)	(dB)	(dB)	(dB)	(dB)	(dB)	(dB)	(dB)	(dB)	(dB)	dB(A)	dB(A)
1	536423.48	4828041.86	365.50	0	500	70.6	70.6	0.0	0.0	61.3	0.6	-1.9	0.0	0.0	5.1	0.0	-0.0	5.5	5.5

Point Source, ISO 9613, Name: "Intake", ID: "S20A"																			
Nr.	X	Y	Z	Refl.	Freq.	LxT	LxN	K0	Dc	Adiv	Aatm	Agr	Afol	Ahous	Abar	Cmet	RL	LrT	LrN
	(m)	(m)	(m)		(Hz)	dB(A)	dB(A)	(dB)	(dB)	(dB)	(dB)	(dB)	(dB)	(dB)	(dB)	(dB)	(dB)	dB(A)	dB(A)
1	536417.36	4828029.73	369.55	0	500	69.6	69.6	0.0	0.0	61.2	0.6	-0.9	0.0	0.0	0.0	0.0	-0.0	8.8	8.8

Point Source, ISO 9613, Name: "Intake", ID: "S20B"																			
Nr.	X	Y	Z	Refl.	Freq.	LxT	LxN	K0	Dc	Adiv	Aatm	Agr	Afol	Ahous	Abar	Cmet	RL	LrT	LrN
	(m)	(m)	(m)		(Hz)	dB(A)	dB(A)	(dB)	(dB)	(dB)	(dB)	(dB)	(dB)	(dB)	(dB)	(dB)	(dB)	dB(A)	dB(A)
1	536422.07	4828029.14	369.55	0	500	69.6	69.6	0.0	0.0	61.3	0.6	-1.0	0.0	0.0	0.0	0.0	-0.0	8.6	8.6

Point Source, ISO 9613, Name: "Transformer", ID: "S21"																			
Nr.	X	Y	Z	Refl.	Freq.	LxT	LxN	K0	Dc	Adiv	Aatm	Agr	Afol	Ahous	Abar	Cmet	RL	LrT	LrN
	(m)	(m)	(m)		(Hz)	dB(A)	dB(A)	(dB)	(dB)	(dB)	(dB)	(dB)	(dB)	(dB)	(dB)	(dB)	(dB)	dB(A)	dB(A)
1	536427.50	4828024.94	365.49	0	32	37.6	37.6	0.0	0.0	61.5	0.0	-4.1	0.0	0.0	6.5	0.0	-0.0	-26.3	-26.3
2	536427.50	4828024.94	365.49	0	63	56.8	56.8	0.0	0.0	61.5	0.0	-4.1	0.0	0.0	8.4	0.0	-0.0	-9.0	-9.0
3	536427.50	4828024.94	365.49	0	125	68.9	68.9	0.0	0.0	61.5	0.1	1.2	0.0	0.0	10.1	0.0	-0.0	-3.9	-3.9
4	536427.50	4828024.94	365.49	0	250	71.4	71.4	0.0	0.0	61.5	0.4	-0.6	0.0	0.0	14.9	0.0	-0.0	-4.7	-4.7
5	536427.50	4828024.94	365.49	0	500	76.8	76.8	0.0	0.0	61.5	0.6	-2.0	0.0	0.0	18.8	0.0	-0.0	-2.1	-2.1
6	536427.50	4828024.94	365.49	0	1000	74.0	74.0	0.0	0.0	61.5	1.2	-2.0	0.0	0.0	22.2	0.0	-0.0	-8.9	-8.9
7	536427.50	4828024.94	365.49	0	2000	70.2	70.2	0.0	0.0	61.5	3.2	-2.0	0.0	0.0	24.2	0.0	-0.0	-16.7	-16.7
8	536427.50	4828024.94	365.49	0	4000	65.0	65.0	0.0	0.0	61.5	10.9	-2.0	0.0	0.0	24.6	0.0	-0.0	-30.0	-30.0
9	536427.50	4828024.94	365.49	0	8000	55.9	55.9	0.0	0.0	61.5	39.0	-2.0	0.0	0.0	24.8	0.0	-0.0	-67.3	-67.3

Line Source, ISO 9613, Name: "Truck Route", ID: "Truck Route"																			
Nr.	X	Y	Z	Refl.	Freq.	LxT	LxN	K0	Dc	Adiv	Aatm	Agr	Afol	Ahous	Abar	Cmet	RL	LrT	LrN
	(m)	(m)	(m)		(Hz)	dB(A)	dB(A)	(dB)	(dB)	(dB)	(dB)	(dB)	(dB)	(dB)	(dB)	(dB)	(dB)	dB(A)	dB(A)
38	536377.79	4827992.70	364.59	1	500	83.1	73.1	0.0	0.0	60.4	0.6	-1.7	0.0	0.0	13.0	0.0	1.0	9.8	-0.3
39	536377.42	4827991.60	364.55	1	500	83.4	73.4	0.0	0.0	60.4	0.6	-1.7	0.0	0.0	13.1	0.0	1.0	10.0	0.0
40	536340.01	4828048.81	365.40	1	500	81.9	71.9	0.0	0.0	59.8	0.5	-1.4	0.0	0.0	4.8	0.0	1.0	17.3	7.3
41	536318.96	4828052.44	365.40	1	500	92.9	82.9	0.0	0.0	59.5	0.5	-1.2	0.0	0.0	9.6	0.0	1.0	23.4	13.4
42	536342.11	4828048.45	365.40	1	500	91.6	81.6	0.0	0.0	61.0	0.6	-1.9	0.0	0.0	21.1	0.0	1.0	9.8	-0.2
43	536347.03	4828047.60	365.40	1	500	85.4	75.4	0.0	0.0	60.9	0.6	-1.9	0.0	0.0	20.8	0.0	1.0	3.9	-6.1
44	536348.03	4828047.42	365.40	1	500	73.0	63.0	0.0	0.0	60.9	0.6	-1.8	0.0	0.0	20.8	0.0	1.0	-8.5	-18.4
45	536355.39	4828044.18	365.53	1	500	90.0	80.0	0.0	0.0	60.7	0.6	-1.8	0.0	0.0	21.1	0.0	1.0	8.4	-1.6
46	536358.42	4828042.55	365.60	1	500	83.6	73.6	0.0	0.0	60.6	0.6	-1.8	0.0	0.0	21.0	0.0	1.0	2.2	-7.8
47	536360.07	4828041.66	365.64	1	500	86.4	76.4	0.0	0.0	60.6	0.6	-1.7	0.0	0.0	20.9	0.0	1.0	5.2	-4.8
48	536361.68	4828040.79	365.67	1	500	83.3	73.3	0.0	0.0	60.5	0.6	-1.7	0.0	0.0	20.7	0.0	1.0	2.1	-7.8
49	536364.74	4828039.14	365.74	1	500	90.1	80.1	0.0	0.0	60.4	0.6	-1.7	0.0	0.0	20.3	0.0	1.0	9.5	-0.5
50	536369.99	4828036.30	365.87	1	500	90.4	80.4	0.0	0.0	60.3	0.6	-1.6	0.0	0.0	18.0	0.0	1.0	12.3	2.3
51	536372.81	4828034.78	365.93	1	500	76.6	66.6	0.0	0.0	60.2	0.6	-1.6	0.0	0.0	8.3	0.0	1.0	8.2	-1.8

Receiver
Name: POR 2 - High Street Residence
ID:
X: 536400.79
Y: 4827726.67
Z: 360.35

Point Source, ISO 9613, Name: "Engine # 1", ID: "S1A"

Nr.	X (m)	Y (m)	Z (m)	Refl.	Freq. (Hz)	LxT dB(A)	LxN dB(A)	K0 (dB)	Dc (dB)	Adiv (dB)	Aatm (dB)	Agr (dB)	Afol (dB)	Ahous (dB)	Abar (dB)	Cmet (dB)	RL (dB)	LrT dB(A)	LrN dB(A)
1	536418.76	4828039.34	372.55	0	32	66.6	66.6	0.0	0.0	60.9	0.0	-3.0	0.0	0.0	0.0	0.0	-0.0	8.7	8.7
2	536418.76	4828039.34	372.55	0	63	88.8	88.8	0.0	0.0	60.9	0.0	-3.0	0.0	0.0	0.0	0.0	-0.0	30.8	30.8
3	536418.76	4828039.34	372.55	0	125	89.9	89.9	0.0	0.0	60.9	0.1	2.6	0.0	0.0	0.0	0.0	-0.0	26.3	26.3
4	536418.76	4828039.34	372.55	0	250	77.4	77.4	0.0	0.0	60.9	0.3	0.7	0.0	0.0	0.0	0.0	-0.0	15.4	15.4
5	536418.76	4828039.34	372.55	0	500	75.8	75.8	0.0	0.0	60.9	0.6	-0.7	0.0	0.0	0.0	0.0	-0.0	15.0	15.0
6	536418.76	4828039.34	372.55	0	1000	76.0	76.0	0.0	0.0	60.9	1.2	-0.7	0.0	0.0	0.0	0.0	-0.0	14.6	14.6
7	536418.76	4828039.34	372.55	0	2000	82.2	82.2	0.0	0.0	60.9	3.0	-0.7	0.0	0.0	0.0	0.0	-0.0	18.9	18.9
8	536418.76	4828039.34	372.55	0	4000	89.0	89.0	0.0	0.0	60.9	10.3	-0.7	0.0	0.0	0.0	0.0	-0.0	18.5	18.5
9	536418.76	4828039.34	372.55	0	8000	90.9	90.9	0.0	0.0	60.9	36.6	-0.7	0.0	0.0	0.0	0.0	-0.0	-6.0	-6.0
10	536418.76	4828039.34	372.55	1	250	77.4	77.4	0.0	0.0	61.6	0.4	0.6	0.0	0.0	0.0	0.0	1.0	13.8	13.8
11	536418.76	4828039.34	372.55	1	500	75.8	75.8	0.0	0.0	61.6	0.7	-0.8	0.0	0.0	0.0	0.0	1.0	13.3	13.3
12	536418.76	4828039.34	372.55	1	1000	76.0	76.0	0.0	0.0	61.6	1.3	-0.8	0.0	0.0	0.0	0.0	1.0	12.9	12.9
13	536418.76	4828039.34	372.55	1	2000	82.2	82.2	0.0	0.0	61.6	3.3	-0.8	0.0	0.0	0.0	0.0	1.0	17.1	17.1
14	536418.76	4828039.34	372.55	1	4000	89.0	89.0	0.0	0.0	61.6	11.2	-0.8	0.0	0.0	0.0	0.0	1.0	16.0	16.0
15	536418.76	4828039.34	372.55	1	8000	90.9	90.9	0.0	0.0	61.6	39.8	-0.8	0.0	0.0	0.0	0.0	1.0	-10.8	-10.8

Point Source, ISO 9613, Name: "Engine # 2", ID: "S1B"

Nr.	X (m)	Y (m)	Z (m)	Refl.	Freq. (Hz)	LxT dB(A)	LxN dB(A)	K0 (dB)	Dc (dB)	Adiv (dB)	Aatm (dB)	Agr (dB)	Afol (dB)	Ahous (dB)	Abar (dB)	Cmet (dB)	RL (dB)	LrT dB(A)	LrN dB(A)
1	536422.75	4828038.88	372.55	0	32	66.6	66.6	0.0	0.0	60.9	0.0	-3.0	0.0	0.0	0.0	0.0	-0.0	8.7	8.7
2	536422.75	4828038.88	372.55	0	63	88.8	88.8	0.0	0.0	60.9	0.0	-3.0	0.0	0.0	0.0	0.0	-0.0	30.8	30.8
3	536422.75	4828038.88	372.55	0	125	89.9	89.9	0.0	0.0	60.9	0.1	2.6	0.0	0.0	0.0	0.0	-0.0	26.3	26.3
4	536422.75	4828038.88	372.55	0	250	77.4	77.4	0.0	0.0	60.9	0.3	0.7	0.0	0.0	0.0	0.0	-0.0	15.5	15.5
5	536422.75	4828038.88	372.55	0	500	75.8	75.8	0.0	0.0	60.9	0.6	-0.7	0.0	0.0	0.0	0.0	-0.0	15.0	15.0
6	536422.75	4828038.88	372.55	0	1000	76.0	76.0	0.0	0.0	60.9	1.2	-0.7	0.0	0.0	0.0	0.0	-0.0	14.6	14.6
7	536422.75	4828038.88	372.55	0	2000	82.2	82.2	0.0	0.0	60.9	3.0	-0.7	0.0	0.0	0.0	0.0	-0.0	18.9	18.9
8	536422.75	4828038.88	372.55	0	4000	89.0	89.0	0.0	0.0	60.9	10.3	-0.7	0.0	0.0	0.0	0.0	-0.0	18.5	18.5
9	536422.75	4828038.88	372.55	0	8000	90.9	90.9	0.0	0.0	60.9	36.6	-0.7	0.0	0.0	0.0	0.0	-0.0	-6.0	-6.0
10	536422.75	4828038.88	372.55	1	250	77.4	77.4	0.0	0.0	61.7	0.4	0.6	0.0	0.0	0.0	0.0	1.0	13.8	13.8
11	536422.75	4828038.88	372.55	1	500	75.8	75.8	0.0	0.0	61.7	0.7	-0.8	0.0	0.0	0.0	0.0	1.0	13.2	13.2
12	536422.75	4828038.88	372.55	1	1000	76.0	76.0	0.0	0.0	61.7	1.3	-0.8	0.0	0.0	0.0	0.0	1.0	12.8	12.8
13	536422.75	4828038.88	372.55	1	2000	82.2	82.2	0.0	0.0	61.7	3.3	-0.8	0.0	0.0	0.0	0.0	1.0	17.0	17.0
14	536422.75	4828038.88	372.55	1	4000	89.0	89.0	0.0	0.0	61.7	11.3	-0.8	0.0	0.0	0.0	0.0	1.0	15.8	15.8
15	536422.75	4828038.88	372.55	1	8000	90.9	90.9	0.0	0.0	61.7	40.2	-0.8	0.0	0.0	0.0	0.0	1.0	-11.2	-11.2

Point Source, ISO 9613, Name: "Biofilter fan", ID: "S2A"

Nr.	X (m)	Y (m)	Z (m)	Refl.	Freq. (Hz)	LxT dB(A)	LxN dB(A)	K0 (dB)	Dc (dB)	Adiv (dB)	Aatm (dB)	Agr (dB)	Afol (dB)	Ahous (dB)	Abar (dB)	Cmet (dB)	RL (dB)	LrT dB(A)	LrN dB(A)
1	536372.00	4828025.02	365.65	0	32	-39.4	-39.4	0.0	0.0	60.5	0.0	-4.0	0.0	0.0	10.4	0.0	-0.0	-106.3	-106.3
2	536372.00	4828025.02	365.65	0	63	88.8	88.8	0.0	0.0	60.5	0.0	-4.0	0.0	0.0	13.3	0.0	-0.0	19.0	19.0
3	536372.00	4828025.02	365.65	0	125	91.9	91.9	0.0	0.0	60.5	0.1	1.0	0.0	0.0	16.0	0.0	-0.0	14.2	14.2
4	536372.00	4828025.02	365.65	0	250	79.4	79.4	0.0	0.0	60.5	0.3	-0.7	0.0	0.0	20.2	0.0	-0.0	-0.9	-0.9
5	536372.00	4828025.02	365.65	0	500	83.8	83.8	0.0	0.0	60.5	0.6	-2.1	0.0	0.0	22.2	0.0	-0.0	2.5	2.5
6	536372.00	4828025.02	365.65	0	1000	83.0	83.0	0.0	0.0	60.5	1.1	-2.1	0.0	0.0	23.4	0.0	-0.0	0.0	0.0
7	536372.00	4828025.02	365.65	0	2000	81.2	81.2	0.0	0.0	60.5	2.9	-2.1	0.0	0.0	24.1	0.0	-0.0	-4.3	-4.3
8	536372.00	4828025.02	365.65	0	4000	73.0	73.0	0.0	0.0	60.5	9.8	-2.1	0.0	0.0	24.5	0.0	-0.0	-19.8	-19.8
9	536372.00	4828025.02	365.65	0	8000	62.9	62.9	0.0	0.0	60.5	35.0	-2.1	0.0	0.0	24.8	0.0	-0.0	-55.4	-55.4

Point Source, ISO 9613, Name: "Biofilter fan", ID: "S2B"

Nr.	X (m)	Y (m)	Z (m)	Refl.	Freq. (Hz)	LxT dB(A)	LxN dB(A)	K0 (dB)	Dc (dB)	Adiv (dB)	Aatm (dB)	Agr (dB)	Afol (dB)	Ahous (dB)	Abar (dB)	Cmet (dB)	RL (dB)	LrT dB(A)	LrN dB(A)
1	536373.92	4828028.71	365.66	0	32	-39.4	-39.4	0.0	0.0	60.6	0.0	-4.1	0.0	0.0	9.1	0.0	-0.0	-105.1	-105.1
2	536373.92	4828028.71	365.66	0	63	88.8	88.8	0.0	0.0	60.6	0.0	-4.1	0.0	0.0	11.8	0.0	-0.0	20.4	20.4

Point Source, ISO 9613, Name: "Biofilter fan", ID: "S2B"																			
Nr.	X	Y	Z	Refl.	Freq.	LxT	LxN	K0	Dc	Adiv	Aatm	Agr	Afol	Ahous	Abar	Cmet	RL	LrT	LrN
	(m)	(m)	(m)		(Hz)	dB(A)	dB(A)	(dB)	(dB)	(dB)	(dB)	(dB)	(dB)	(dB)	(dB)	(dB)	(dB)	dB(A)	dB(A)
3	536373.92	4828028.71	365.66	0	125	91.9	91.9	0.0	0.0	60.6	0.1	1.0	0.0	0.0	14.5	0.0	-0.0	15.6	15.6
4	536373.92	4828028.71	365.66	0	250	79.4	79.4	0.0	0.0	60.6	0.3	-0.7	0.0	0.0	18.3	0.0	-0.0	0.9	0.9
5	536373.92	4828028.71	365.66	0	500	83.8	83.8	0.0	0.0	60.6	0.6	-2.1	0.0	0.0	20.7	0.0	-0.0	4.0	4.0
6	536373.92	4828028.71	365.66	0	1000	83.0	83.0	0.0	0.0	60.6	1.1	-2.1	0.0	0.0	22.3	0.0	-0.0	1.1	1.1
7	536373.92	4828028.71	365.66	0	2000	81.2	81.2	0.0	0.0	60.6	2.9	-2.1	0.0	0.0	23.4	0.0	-0.0	-3.7	-3.7
8	536373.92	4828028.71	365.66	0	4000	73.0	73.0	0.0	0.0	60.6	9.9	-2.1	0.0	0.0	24.1	0.0	-0.0	-19.6	-19.6
9	536373.92	4828028.71	365.66	0	8000	62.9	62.9	0.0	0.0	60.6	35.4	-2.1	0.0	0.0	24.6	0.0	-0.0	-55.6	-55.6

Point Source, ISO 9613, Name: "Agitator 1", ID: "S4"																			
Nr.	X	Y	Z	Refl.	Freq.	LxT	LxN	K0	Dc	Adiv	Aatm	Agr	Afol	Ahous	Abar	Cmet	RL	LrT	LrN
	(m)	(m)	(m)		(Hz)	dB(A)	dB(A)	(dB)	(dB)	(dB)	(dB)	(dB)	(dB)	(dB)	(dB)	(dB)	(dB)	dB(A)	dB(A)
1	536331.65	4828009.55	369.56	0	500	82.0	82.0	0.0	0.0	60.3	0.6	-0.7	0.0	0.0	21.1	0.0	-0.0	0.8	0.8
2	536331.65	4828009.55	369.56	1	500	82.0	82.0	0.0	0.0	61.1	0.6	-1.0	0.0	0.0	14.4	0.0	1.0	5.8	5.8

Point Source, ISO 9613, Name: "Agitator 2", ID: "S5"																			
Nr.	X	Y	Z	Refl.	Freq.	LxT	LxN	K0	Dc	Adiv	Aatm	Agr	Afol	Ahous	Abar	Cmet	RL	LrT	LrN
	(m)	(m)	(m)		(Hz)	dB(A)	dB(A)	(dB)	(dB)	(dB)	(dB)	(dB)	(dB)	(dB)	(dB)	(dB)	(dB)	dB(A)	dB(A)
1	536312.63	4827995.86	368.92	0	500	82.0	82.0	0.0	0.0	60.0	0.6	-0.6	0.0	0.0	17.5	0.0	-0.0	4.6	4.6
2	536312.63	4827995.86	368.92	1	500	82.0	82.0	0.0	0.0	61.7	0.7	-1.1	0.0	0.0	25.0	0.0	1.0	-5.2	-5.2

Point Source, ISO 9613, Name: "Agitator 3", ID: "S6"																			
Nr.	X	Y	Z	Refl.	Freq.	LxT	LxN	K0	Dc	Adiv	Aatm	Agr	Afol	Ahous	Abar	Cmet	RL	LrT	LrN
	(m)	(m)	(m)		(Hz)	dB(A)	dB(A)	(dB)	(dB)	(dB)	(dB)	(dB)	(dB)	(dB)	(dB)	(dB)	(dB)	dB(A)	dB(A)
1	536332.71	4827992.63	369.53	0	500	82.0	82.0	0.0	0.0	59.8	0.5	-0.6	0.0	0.0	0.0	0.0	-0.0	22.3	22.3

Point Source, ISO 9613, Name: "Agitator 4", ID: "S7"																			
Nr.	X	Y	Z	Refl.	Freq.	LxT	LxN	K0	Dc	Adiv	Aatm	Agr	Afol	Ahous	Abar	Cmet	RL	LrT	LrN
	(m)	(m)	(m)		(Hz)	dB(A)	dB(A)	(dB)	(dB)	(dB)	(dB)	(dB)	(dB)	(dB)	(dB)	(dB)	(dB)	dB(A)	dB(A)
1	536342.47	4827997.19	369.23	0	500	82.0	82.0	0.0	0.0	59.8	0.5	-0.6	0.0	0.0	18.4	0.0	-0.0	3.8	3.8

Point Source, ISO 9613, Name: "Agitator 5", ID: "S8"																			
Nr.	X	Y	Z	Refl.	Freq.	LxT	LxN	K0	Dc	Adiv	Aatm	Agr	Afol	Ahous	Abar	Cmet	RL	LrT	LrN
	(m)	(m)	(m)		(Hz)	dB(A)	dB(A)	(dB)	(dB)	(dB)	(dB)	(dB)	(dB)	(dB)	(dB)	(dB)	(dB)	dB(A)	dB(A)
1	536360.09	4827985.34	369.74	0	500	82.0	82.0	0.0	0.0	59.4	0.5	-0.6	0.0	0.0	0.0	0.0	-0.0	22.7	22.7

Point Source, ISO 9613, Name: "Agitator 6", ID: "S9"																			
Nr.	X	Y	Z	Refl.	Freq.	LxT	LxN	K0	Dc	Adiv	Aatm	Agr	Afol	Ahous	Abar	Cmet	RL	LrT	LrN
	(m)	(m)	(m)		(Hz)	dB(A)	dB(A)	(dB)	(dB)	(dB)	(dB)	(dB)	(dB)	(dB)	(dB)	(dB)	(dB)	dB(A)	dB(A)
1	536342.19	4827976.06	369.87	0	500	82.0	82.0	0.0	0.0	59.2	0.5	-0.5	0.0	0.0	0.0	0.0	-0.0	22.8	22.8
2	536342.19	4827976.06	369.87	1	500	82.0	82.0	0.0	0.0	59.2	0.5	-0.5	0.0	0.0	0.0	0.0	1.0	21.8	21.8

Point Source, ISO 9613, Name: "Agitator 7", ID: "S10"																			
Nr.	X	Y	Z	Refl.	Freq.	LxT	LxN	K0	Dc	Adiv	Aatm	Agr	Afol	Ahous	Abar	Cmet	RL	LrT	LrN
	(m)	(m)	(m)		(Hz)	dB(A)	dB(A)	(dB)	(dB)	(dB)	(dB)	(dB)	(dB)	(dB)	(dB)	(dB)	(dB)	dB(A)	dB(A)
1	536327.57	4827985.16	368.45	0	500	82.0	82.0	0.0	0.0	59.6	0.5	-0.6	0.0	0.0	17.1	0.0	-0.0	5.3	5.3

Point Source, ISO 9613, Name: "Agitator 8", ID: "S11"																			
Nr.	X	Y	Z	Refl.	Freq.	LxT	LxN	K0	Dc	Adiv	Aatm	Agr	Afol	Ahous	Abar	Cmet	RL	LrT	LrN
	(m)	(m)	(m)		(Hz)	dB(A)	dB(A)	(dB)	(dB)	(dB)	(dB)	(dB)	(dB)	(dB)	(dB)	(dB)	(dB)	dB(A)	dB(A)
1	536336.44	4827966.69	368.58	0	500	82.0	82.0	0.0	0.0	58.9	0.5	-0.4	0.0	0.0	0.0	0.0	-0.0	23.0	23.0

Point Source, ISO 9613, Name: "Agitator 9", ID: "S12"																			
Nr.	X	Y	Z	Refl.	Freq.	LxT	LxN	K0	Dc	Adiv	Aatm	Agr	Afol	Ahous	Abar	Cmet	RL	LrT	LrN
	(m)	(m)	(m)		(Hz)	dB(A)	dB(A)	(dB)	(dB)	(dB)	(dB)	(dB)	(dB)	(dB)	(dB)	(dB)	(dB)	dB(A)	dB(A)
1	536317.58	4827959.11	367.79	0	500	82.0	82.0	0.0	0.0	58.8	0.5	-0.4	0.0	0.0	0.0	0.0	-0.0	23.0	23.0

Point Source, ISO 9613, Name: "Agitator 10", ID: "S13"																			
Nr.	X	Y	Z	Refl.	Freq.	LxT	LxN	K0	Dc	Adiv	Aatm	Agr	Afol	Ahous	Abar	Cmet	RL	LrT	LrN
	(m)	(m)	(m)		(Hz)	dB(A)	dB(A)	(dB)	(dB)	(dB)	(dB)	(dB)	(dB)	(dB)	(dB)	(dB)	(dB)	dB(A)	dB(A)
1	536311.13	4827978.47	368.65	0	500	82.0	82.0	0.0	0.0	59.5	0.5	-0.5	0.0	0.0	15.6	0.0	-0.0	6.9	6.9

Point Source, ISO 9613, Name: "Agitator 11", ID: "S14"																			
Nr.	X	Y	Z	Refl.	Freq.	LxT	LxN	K0	Dc	Adiv	Aatm	Agr	Afol	Ahous	Abar	Cmet	RL	LrT	LrN
	(m)	(m)	(m)		(Hz)	dB(A)	dB(A)	(dB)	(dB)	(dB)	(dB)	(dB)	(dB)	(dB)	(dB)	(dB)	(dB)	dB(A)	dB(A)
1	536327.35	4828019.36	368.87	0	500	93.0	93.0	0.0	0.0	60.6	0.6	-1.0	0.0	0.0	20.2	0.0	-0.0	12.5	12.5
2	536327.35	4828019.36	368.87	1	500	93.0	93.0	0.0	0.0	61.1	0.6	-1.1	0.0	0.0	19.0	0.0	1.0	12.4	12.4

Point Source, ISO 9613, Name: "Agitator 12", ID: "S15"																			
Nr.	X	Y	Z	Refl.	Freq.	LxT	LxN	K0	Dc	Adiv	Aatm	Agr	Afol	Ahous	Abar	Cmet	RL	LrT	LrN
	(m)	(m)	(m)		(Hz)	dB(A)	dB(A)	(dB)	(dB)	(dB)	(dB)	(dB)	(dB)	(dB)	(dB)	(dB)	(dB)	dB(A)	dB(A)
1	536339.00	4828012.25	368.94	0	500	93.0	93.0	0.0	0.0	60.3	0.6	-0.9	0.0	0.0	15.2	0.0	-0.0	17.8	17.8
2	536339.00	4828012.25	368.94	1	500	93.0	93.0	0.0	0.0	60.3	0.6	-0.9	0.0	0.0	20.5	0.0	1.0	11.5	11.5
3	536339.00	4828012.25	368.94	1	500	93.0	93.0	0.0	0.0	60.8	0.6	-1.1	0.0	0.0	19.2	0.0	1.0	12.5	12.5

Point Source, ISO 9613, Name: "Agitator 13", ID: "S16"																			
Nr.	X	Y	Z	Refl.	Freq.	LxT	LxN	K0	Dc	Adiv	Aatm	Agr	Afol	Ahous	Abar	Cmet	RL	LrT	LrN
	(m)	(m)	(m)		(Hz)	dB(A)	dB(A)	(dB)	(dB)	(dB)	(dB)	(dB)	(dB)	(dB)	(dB)	(dB)	(dB)	dB(A)	dB(A)
1	536350.13	4828005.98	369.22	0	500	93.0	93.0	0.0	0.0	60.1	0.6	-0.8	0.0	0.0	14.7	0.0	-0.0	18.4	18.4
2	536350.13	4828005.98	369.22	1	500	93.0	93.0	0.0	0.0	60.4	0.6	-0.9	0.0	0.0	0.0	0.0	1.0	31.9	31.9
3	536350.13	4828005.98	369.22	1	500	93.0	93.0	0.0	0.0	60.6	0.6	-1.0	0.0	0.0	4.9	0.0	1.0	26.9	26.9

Point Source, ISO 9613, Name: "Agitator 17", ID: "S17"																			
Nr.	X	Y	Z	Refl.	Freq.	LxT	LxN	K0	Dc	Adiv	Aatm	Agr	Afol	Ahous	Abar	Cmet	RL	LrT	LrN
	(m)	(m)	(m)		(Hz)	dB(A)	dB(A)	(dB)	(dB)	(dB)	(dB)	(dB)	(dB)	(dB)	(dB)	(dB)	(dB)	dB(A)	dB(A)
1	536351.78	4828004.07	369.22	0	500	93.0	93.0	0.0	0.0	60.0	0.5	-0.7	0.0	0.0	14.0	0.0	-0.0	19.1	19.1
2	536351.78	4828004.07	369.22	1	500	93.0	93.0	0.0	0.0	60.4	0.6	-0.8	0.0	0.0	0.0	0.0	1.0	31.8	31.8

Point Source, ISO 9613, Name: "Radiator", ID: "S18A"																			
Nr.	X	Y	Z	Refl.	Freq.	LxT	LxN	K0	Dc	Adiv	Aatm	Agr	Afol	Ahous	Abar	Cmet	RL	LrT	LrN
	(m)	(m)	(m)		(Hz)	dB(A)	dB(A)	(dB)	(dB)	(dB)	(dB)	(dB)	(dB)	(dB)	(dB)	(dB)	(dB)	dB(A)	dB(A)
1	536418.39	4828045.06	365.00	0	500	97.0	97.0	0.0	0.0	61.1	0.6	-2.2	0.0	0.0	13.1	0.0	-0.0	24.5	24.5
2	536418.39	4828045.06	365.00	1	500	97.0	97.0	0.0	0.0	61.7	0.7	-2.4	0.0	0.0	4.8	0.0	1.0	31.2	31.2

Point Source, ISO 9613, Name: "Radiator", ID: "S18B"																			
Nr.	X	Y	Z	Refl.	Freq.	LxT	LxN	K0	Dc	Adiv	Aatm	Agr	Afol	Ahous	Abar	Cmet	RL	LrT	LrN
	(m)	(m)	(m)		(Hz)	dB(A)	dB(A)	(dB)	(dB)	(dB)	(dB)	(dB)	(dB)	(dB)	(dB)	(dB)	(dB)	dB(A)	dB(A)
1	536424.61	4828044.37	365.00	0	500	97.0	97.0	0.0	0.0	61.1	0.6	-2.2	0.0	0.0	10.8	0.0	-0.0	26.7	26.7
2	536424.61	4828044.37	365.00	1	500	97.0	97.0	0.0	0.0	61.8	0.7	-2.4	0.0	0.0	18.0	0.0	1.0	17.9	17.9

Point Source, ISO 9613, Name: "Discharge", ID: "S19A"																			
Nr.	X	Y	Z	Refl.	Freq.	LxT	LxN	K0	Dc	Adiv	Aatm	Agr	Afol	Ahous	Abar	Cmet	RL	LrT	LrN
	(m)	(m)	(m)		(Hz)	dB(A)	dB(A)	(dB)	(dB)	(dB)	(dB)	(dB)	(dB)	(dB)	(dB)	(dB)	(dB)	dB(A)	dB(A)
1	536418.68	4828042.44	365.50	0	500	70.6	70.6	0.0	0.0	61.0	0.6	-2.1	0.0	0.0	16.8	0.0	-0.0	-5.7	-5.7
2	536418.68	4828042.44	365.50	1	500	70.6	70.6	0.0	0.0	61.7	0.7	-2.2	0.0	0.0	21.1	0.0	1.0	-11.6	-11.6

Point Source, ISO 9613, Name: "Discharge", ID: "S19B"																			
Nr.	X	Y	Z	Refl.	Freq.	LxT	LxN	K0	Dc	Adiv	Aatm	Agr	Afol	Ahous	Abar	Cmet	RL	LrT	LrN
	(m)	(m)	(m)		(Hz)	dB(A)	dB(A)	(dB)	(dB)	(dB)	(dB)	(dB)	(dB)	(dB)	(dB)	(dB)	(dB)	dB(A)	dB(A)
1	536423.48	4828041.86	365.50	0	500	70.6	70.6	0.0	0.0	61.0	0.6	-2.1	0.0	0.0	16.5	0.0	-0.0	-5.4	-5.4
2	536423.48	4828041.86	365.50	1	500	70.6	70.6	0.0	0.0	61.8	0.7	-2.3	0.0	0.0	23.4	0.0	1.0	-14.0	-14.0

Point Source, ISO 9613, Name: "Intake", ID: "S20A"																			
Nr.	X	Y	Z	Refl.	Freq.	LxT	LxN	K0	Dc	Adiv	Aatm	Agr	Afol	Ahous	Abar	Cmet	RL	LrT	LrN
	(m)	(m)	(m)		(Hz)	dB(A)	dB(A)	(dB)	(dB)	(dB)	(dB)	(dB)	(dB)	(dB)	(dB)	(dB)	(dB)	dB(A)	dB(A)
1	536417.36	4828029.73	369.55	0	500	69.6	69.6	0.0	0.0	60.6	0.6	-1.0	0.0	0.0	4.8	0.0	-0.0	4.6	4.6
2	536417.36	4828029.73	369.55	1	500	69.6	69.6	0.0	0.0	61.5	0.7	-1.2	0.0	0.0	0.0	0.0	1.0	7.7	7.7

Point Source, ISO 9613, Name: "Intake", ID: "S20B"																			
Nr.	X	Y	Z	Refl.	Freq.	LxT	LxN	K0	Dc	Adiv	Aatm	Agr	Afol	Ahous	Abar	Cmet	RL	LrT	LrN
	(m)	(m)	(m)		(Hz)	dB(A)	dB(A)	(dB)	(dB)	(dB)	(dB)	(dB)	(dB)	(dB)	(dB)	(dB)	(dB)	dB(A)	dB(A)
1	536422.07	4828029.14	369.55	0	500	69.6	69.6	0.0	0.0	60.6	0.6	-1.0	0.0	0.0	4.8	0.0	-0.0	4.6	4.6

Point Source, ISO 9613, Name: "Transformer", ID: "S21"																			
Nr.	X	Y	Z	Refl.	Freq.	LxT	LxN	K0	Dc	Adiv	Aatm	Agr	Afol	Ahous	Abar	Cmet	RL	LrT	LrN
	(m)	(m)	(m)		(Hz)	dB(A)	dB(A)	(dB)	(dB)	(dB)	(dB)	(dB)	(dB)	(dB)	(dB)	(dB)	(dB)	dB(A)	dB(A)
1	536427.50	4828024.94	365.49	0	32	37.6	37.6	0.0	0.0	60.5	0.0	-3.9	0.0	0.0	4.8	0.0	-0.0	-23.8	-23.8
2	536427.50	4828024.94	365.49	0	63	56.8	56.8	0.0	0.0	60.5	0.0	-3.9	0.0	0.0	4.8	0.0	-0.0	-4.6	-4.6
3	536427.50	4828024.94	365.49	0	125	68.9	68.9	0.0	0.0	60.5	0.1	1.2	0.0	0.0	3.6	0.0	-0.0	3.5	3.5

Line Source, ISO 9613, Name: "Truck Route", ID: "Truck Route"																			
Nr.	X	Y	Z	Refl.	Freq.	LxT	LxN	K0	Dc	Adiv	Aatm	Agr	Afol	Ahous	Abar	Cmet	RL	LrT	LrN
	(m)	(m)	(m)		(Hz)	dB(A)	dB(A)	(dB)	(dB)	(dB)	(dB)	(dB)	(dB)	(dB)	(dB)	(dB)	(dB)	dB(A)	dB(A)
29	536307.59	4827960.68	363.09	0	500	91.5	81.5	0.0	0.0	59.0	0.5	-0.9	0.0	0.0	0.0	0.0	-0.0	32.8	22.8
30	536388.26	4828023.30	365.79	1	500	89.7	79.7	0.0	0.0	60.7	0.6	-2.0	0.0	0.0	0.0	0.0	1.0	29.4	19.4
31	536387.10	4828019.91	365.65	1	500	85.4	75.4	0.0	0.0	60.6	0.6	-2.0	0.0	0.0	0.0	0.0	1.0	25.2	15.2
32	536386.23	4828017.35	365.56	1	500	87.9	77.9	0.0	0.0	60.6	0.6	-2.0	0.0	0.0	0.0	0.0	1.0	27.7	17.7
33	536385.54	4828015.33	365.48	1	500	81.7	71.7	0.0	0.0	60.6	0.6	-2.0	0.0	0.0	10.5	0.0	1.0	11.0	1.0
34	536384.52	4828028.33	365.95	1	500	84.5	74.5	0.0	0.0	60.7	0.6	-2.0	0.0	0.0	0.0	0.0	1.0	24.2	14.2
35	536387.16	4828026.86	365.91	1	500	89.0	79.0	0.0	0.0	60.7	0.6	-2.0	0.0	0.0	0.0	0.0	1.0	28.7	18.7

Receiver

Name: POR 3 - Township Road 14 Residence

ID:

X: 536240.66

Y: 4828258.81

Z: 364.29

Point Source, ISO 9613, Name: "Engine # 1", ID: "S1A"

Nr.	X (m)	Y (m)	Z (m)	Refl.	Freq. (Hz)	LxT dB(A)	LxN dB(A)	K0 (dB)	Dc (dB)	Adiv (dB)	Aatm (dB)	Agr (dB)	Afol (dB)	Ahous (dB)	Abar (dB)	Cmet (dB)	RL (dB)	LrT dB(A)	LrN dB(A)
1	536418.76	4828039.34	372.55	0	32	66.6	66.6	0.0	0.0	60.0	0.0	-3.0	0.0	0.0	0.0	0.0	-0.0	9.6	9.6
2	536418.76	4828039.34	372.55	0	63	88.8	88.8	0.0	0.0	60.0	0.0	-3.0	0.0	0.0	0.0	0.0	-0.0	31.7	31.7
3	536418.76	4828039.34	372.55	0	125	89.9	89.9	0.0	0.0	60.0	0.1	3.2	0.0	0.0	0.0	0.0	-0.0	26.5	26.5
4	536418.76	4828039.34	372.55	0	250	77.4	77.4	0.0	0.0	60.0	0.3	1.3	0.0	0.0	0.0	0.0	-0.0	15.8	15.8
5	536418.76	4828039.34	372.55	0	500	75.8	75.8	0.0	0.0	60.0	0.6	-0.1	0.0	0.0	0.0	0.0	-0.0	15.3	15.3
6	536418.76	4828039.34	372.55	0	1000	76.0	76.0	0.0	0.0	60.0	1.0	-0.1	0.0	0.0	0.0	0.0	-0.0	15.0	15.0
7	536418.76	4828039.34	372.55	0	2000	82.2	82.2	0.0	0.0	60.0	2.7	-0.1	0.0	0.0	0.0	0.0	-0.0	19.5	19.5
8	536418.76	4828039.34	372.55	0	4000	89.0	89.0	0.0	0.0	60.0	9.3	-0.1	0.0	0.0	0.0	0.0	-0.0	19.8	19.8
9	536418.76	4828039.34	372.55	0	8000	90.9	90.9	0.0	0.0	60.0	33.0	-0.1	0.0	0.0	0.0	0.0	-0.0	-2.1	-2.1
10	536418.76	4828039.34	372.55	1	250	77.4	77.4	0.0	0.0	61.2	0.3	0.8	0.0	0.0	0.0	0.0	1.0	14.0	14.0
11	536418.76	4828039.34	372.55	1	500	75.8	75.8	0.0	0.0	61.2	0.6	-0.6	0.0	0.0	0.0	0.0	1.0	13.5	13.5
12	536418.76	4828039.34	372.55	1	1000	76.0	76.0	0.0	0.0	61.2	1.2	-0.6	0.0	0.0	0.0	0.0	1.0	13.2	13.2
13	536418.76	4828039.34	372.55	1	2000	82.2	82.2	0.0	0.0	61.2	3.1	-0.6	0.0	0.0	0.0	0.0	1.0	17.4	17.4
14	536418.76	4828039.34	372.55	1	4000	89.0	89.0	0.0	0.0	61.2	10.6	-0.6	0.0	0.0	0.0	0.0	1.0	16.7	16.7
15	536418.76	4828039.34	372.55	1	8000	90.9	90.9	0.0	0.0	61.2	37.9	-0.6	0.0	0.0	0.0	0.0	1.0	-8.7	-8.7

Point Source, ISO 9613, Name: "Engine # 2", ID: "S1B"

Nr.	X (m)	Y (m)	Z (m)	Refl.	Freq. (Hz)	LxT dB(A)	LxN dB(A)	K0 (dB)	Dc (dB)	Adiv (dB)	Aatm (dB)	Agr (dB)	Afol (dB)	Ahous (dB)	Abar (dB)	Cmet (dB)	RL (dB)	LrT dB(A)	LrN dB(A)
1	536422.75	4828038.88	372.55	0	32	66.6	66.6	0.0	0.0	60.1	0.0	-3.0	0.0	0.0	0.0	0.0	-0.0	9.5	9.5
2	536422.75	4828038.88	372.55	0	63	88.8	88.8	0.0	0.0	60.1	0.0	-3.0	0.0	0.0	0.0	0.0	-0.0	31.6	31.6
3	536422.75	4828038.88	372.55	0	125	89.9	89.9	0.0	0.0	60.1	0.1	3.2	0.0	0.0	0.0	0.0	-0.0	26.4	26.4
4	536422.75	4828038.88	372.55	0	250	77.4	77.4	0.0	0.0	60.1	0.3	1.3	0.0	0.0	0.0	0.0	-0.0	15.7	15.7
5	536422.75	4828038.88	372.55	0	500	75.8	75.8	0.0	0.0	60.1	0.6	-0.1	0.0	0.0	0.0	0.0	-0.0	15.2	15.2
6	536422.75	4828038.88	372.55	0	1000	76.0	76.0	0.0	0.0	60.1	1.0	-0.1	0.0	0.0	0.0	0.0	-0.0	14.9	14.9
7	536422.75	4828038.88	372.55	0	2000	82.2	82.2	0.0	0.0	60.1	2.8	-0.1	0.0	0.0	0.0	0.0	-0.0	19.4	19.4
8	536422.75	4828038.88	372.55	0	4000	89.0	89.0	0.0	0.0	60.1	9.4	-0.1	0.0	0.0	0.0	0.0	-0.0	19.6	19.6
9	536422.75	4828038.88	372.55	0	8000	90.9	90.9	0.0	0.0	60.1	33.4	-0.1	0.0	0.0	0.0	0.0	-0.0	-2.5	-2.5
10	536422.75	4828038.88	372.55	1	250	77.4	77.4	0.0	0.0	61.3	0.3	0.8	0.0	0.0	0.0	0.0	1.0	13.9	13.9
11	536422.75	4828038.88	372.55	1	500	75.8	75.8	0.0	0.0	61.3	0.6	-0.6	0.0	0.0	0.0	0.0	1.0	13.4	13.4
12	536422.75	4828038.88	372.55	1	1000	76.0	76.0	0.0	0.0	61.3	1.2	-0.6	0.0	0.0	0.0	0.0	1.0	13.1	13.1
13	536422.75	4828038.88	372.55	1	2000	82.2	82.2	0.0	0.0	61.3	3.2	-0.6	0.0	0.0	0.0	0.0	1.0	17.3	17.3
14	536422.75	4828038.88	372.55	1	4000	89.0	89.0	0.0	0.0	61.3	10.8	-0.6	0.0	0.0	0.0	0.0	1.0	16.5	16.5
15	536422.75	4828038.88	372.55	1	8000	90.9	90.9	0.0	0.0	61.3	38.4	-0.6	0.0	0.0	0.0	0.0	1.0	-9.2	-9.2

Point Source, ISO 9613, Name: "Biofilter fan", ID: "S2A"

Nr.	X (m)	Y (m)	Z (m)	Refl.	Freq. (Hz)	LxT dB(A)	LxN dB(A)	K0 (dB)	Dc (dB)	Adiv (dB)	Aatm (dB)	Agr (dB)	Afol (dB)	Ahous (dB)	Abar (dB)	Cmet (dB)	RL (dB)	LrT dB(A)	LrN dB(A)
1	536372.00	4828025.02	365.65	0	32	-39.4	-39.4	0.0	0.0	59.6	0.0	-3.8	0.0	0.0	2.8	0.0	-0.0	-98.0	-98.0
2	536372.00	4828025.02	365.65	0	63	88.8	88.8	0.0	0.0	59.6	0.0	-3.8	0.0	0.0	3.4	0.0	-0.0	29.6	29.6
3	536372.00	4828025.02	365.65	0	125	91.9	91.9	0.0	0.0	59.6	0.1	2.6	0.0	0.0	2.0	0.0	-0.0	27.7	27.7
4	536372.00	4828025.02	365.65	0	250	79.4	79.4	0.0	0.0	59.6	0.3	2.2	0.0	0.0	3.0	0.0	-0.0	14.4	14.4
5	536372.00	4828025.02	365.65	0	500	83.8	83.8	0.0	0.0	59.6	0.5	-0.4	0.0	0.0	5.8	0.0	-0.0	18.2	18.2
6	536372.00	4828025.02	365.65	0	1000	83.0	83.0	0.0	0.0	59.6	1.0	-1.0	0.0	0.0	7.1	0.0	-0.0	16.3	16.3
7	536372.00	4828025.02	365.65	0	2000	81.2	81.2	0.0	0.0	59.6	2.6	-1.0	0.0	0.0	8.9	0.0	-0.0	11.2	11.2
8	536372.00	4828025.02	365.65	0	4000	73.0	73.0	0.0	0.0	59.6	8.8	-1.0	0.0	0.0	11.1	0.0	-0.0	-5.4	-5.4
9	536372.00	4828025.02	365.65	0	8000	62.9	62.9	0.0	0.0	59.6	31.3	-1.0	0.0	0.0	13.6	0.0	-0.0	-40.6	-40.6
10	536372.00	4828025.02	365.65	1	8000	62.9	62.9	0.0	0.0	61.8	40.5	-2.2	0.0	0.0	25.0	0.0	1.0	-63.3	-63.3
11	536372.00	4828025.02	365.65	1	125	91.9	91.9	0.0	0.0	59.6	0.1	2.3	0.0	0.0	2.6	0.0	1.0	26.2	26.2
12	536372.00	4828025.02	365.65	1	250	79.4	79.4	0.0	0.0	59.6	0.3	1.6	0.0	0.0	3.6	0.0	1.0	13.3	13.3
13	536372.00	4828025.02	365.65	1	500	83.8	83.8	0.0	0.0	59.6	0.5	-0.7	0.0	0.0	5.9	0.0	1.0	17.4	17.4
14	536372.00	4828025.02	365.65	1	1000	83.0	83.0	0.0	0.0	59.6	1.0	-1.1	0.0	0.0	7.2	0.0	1.0	15.3	15.3
15	536372.00	4828025.02	365.65	1	2000	81.2	81.2	0.0	0.0	59.6	2.6	-1.2	0.0	0.0	9.0	0.0	1.0	10.1	10.1

Point Source, ISO 9613, Name: "Agitator 2", ID: "S5"																			
Nr.	X	Y	Z	Refl.	Freq.	LxT	LxN	K0	Dc	Adiv	Aatm	Agr	Afol	Ahous	Abar	Cmet	RL	LrT	LrN
	(m)	(m)	(m)		(Hz)	dB(A)	dB(A)	(dB)	(dB)	(dB)	(dB)	(dB)	(dB)	(dB)	(dB)	(dB)	(dB)	dB(A)	dB(A)
1	536312.63	4827995.86	368.92	0	500	82.0	82.0	0.0	0.0	59.7	0.5	-0.3	0.0	0.0	4.8	0.0	-0.0	17.3	17.3

Point Source, ISO 9613, Name: "Agitator 3", ID: "S6"																			
Nr.	X	Y	Z	Refl.	Freq.	LxT	LxN	K0	Dc	Adiv	Aatm	Agr	Afol	Ahous	Abar	Cmet	RL	LrT	LrN
	(m)	(m)	(m)		(Hz)	dB(A)	dB(A)	(dB)	(dB)	(dB)	(dB)	(dB)	(dB)	(dB)	(dB)	(dB)	(dB)	dB(A)	dB(A)
1	536332.71	4827992.63	369.53	0	500	82.0	82.0	0.0	0.0	60.0	0.5	-0.6	0.0	0.0	0.0	0.0	-0.0	22.0	22.0

Point Source, ISO 9613, Name: "Agitator 4", ID: "S7"																			
Nr.	X	Y	Z	Refl.	Freq.	LxT	LxN	K0	Dc	Adiv	Aatm	Agr	Afol	Ahous	Abar	Cmet	RL	LrT	LrN
	(m)	(m)	(m)		(Hz)	dB(A)	dB(A)	(dB)	(dB)	(dB)	(dB)	(dB)	(dB)	(dB)	(dB)	(dB)	(dB)	dB(A)	dB(A)
1	536342.47	4827997.19	369.23	0	500	82.0	82.0	0.0	0.0	60.0	0.5	-0.5	0.0	0.0	4.8	0.0	-0.0	17.2	17.2

Point Source, ISO 9613, Name: "Agitator 5", ID: "S8"																			
Nr.	X	Y	Z	Refl.	Freq.	LxT	LxN	K0	Dc	Adiv	Aatm	Agr	Afol	Ahous	Abar	Cmet	RL	LrT	LrN
	(m)	(m)	(m)		(Hz)	dB(A)	dB(A)	(dB)	(dB)	(dB)	(dB)	(dB)	(dB)	(dB)	(dB)	(dB)	(dB)	dB(A)	dB(A)
1	536360.09	4827985.34	369.74	0	500	82.0	82.0	0.0	0.0	60.5	0.6	-0.6	0.0	0.0	22.7	0.0	-0.0	-1.1	-1.1

Point Source, ISO 9613, Name: "Agitator 6", ID: "S9"																			
Nr.	X	Y	Z	Refl.	Freq.	LxT	LxN	K0	Dc	Adiv	Aatm	Agr	Afol	Ahous	Abar	Cmet	RL	LrT	LrN
	(m)	(m)	(m)		(Hz)	dB(A)	dB(A)	(dB)	(dB)	(dB)	(dB)	(dB)	(dB)	(dB)	(dB)	(dB)	(dB)	dB(A)	dB(A)
1	536342.19	4827976.06	369.87	0	500	82.0	82.0	0.0	0.0	60.6	0.6	-0.7	0.0	0.0	23.2	0.0	-0.0	-1.7	-1.7

Point Source, ISO 9613, Name: "Agitator 7", ID: "S10"																			
Nr.	X	Y	Z	Refl.	Freq.	LxT	LxN	K0	Dc	Adiv	Aatm	Agr	Afol	Ahous	Abar	Cmet	RL	LrT	LrN
	(m)	(m)	(m)		(Hz)	dB(A)	dB(A)	(dB)	(dB)	(dB)	(dB)	(dB)	(dB)	(dB)	(dB)	(dB)	(dB)	dB(A)	dB(A)
1	536327.57	4827985.16	368.45	0	500	82.0	82.0	0.0	0.0	60.2	0.6	-0.6	0.0	0.0	19.5	0.0	-0.0	2.3	2.3

Point Source, ISO 9613, Name: "Agitator 8", ID: "S11"																			
Nr.	X	Y	Z	Refl.	Freq.	LxT	LxN	K0	Dc	Adiv	Aatm	Agr	Afol	Ahous	Abar	Cmet	RL	LrT	LrN
	(m)	(m)	(m)		(Hz)	dB(A)	dB(A)	(dB)	(dB)	(dB)	(dB)	(dB)	(dB)	(dB)	(dB)	(dB)	(dB)	dB(A)	dB(A)
1	536336.44	4827966.69	368.58	0	500	82.0	82.0	0.0	0.0	60.8	0.6	-0.7	0.0	0.0	22.8	0.0	-0.0	-1.4	-1.4

Point Source, ISO 9613, Name: "Agitator 9", ID: "S12"																			
Nr.	X	Y	Z	Refl.	Freq.	LxT	LxN	K0	Dc	Adiv	Aatm	Agr	Afol	Ahous	Abar	Cmet	RL	LrT	LrN
	(m)	(m)	(m)		(Hz)	dB(A)	dB(A)	(dB)	(dB)	(dB)	(dB)	(dB)	(dB)	(dB)	(dB)	(dB)	(dB)	dB(A)	dB(A)
1	536317.58	4827959.11	367.79	0	500	82.0	82.0	0.0	0.0	60.8	0.6	-0.5	0.0	0.0	16.3	0.0	-0.0	4.8	4.8

Point Source, ISO 9613, Name: "Agitator 10", ID: "S13"																			
Nr.	X	Y	Z	Refl.	Freq.	LxT	LxN	K0	Dc	Adiv	Aatm	Agr	Afol	Ahous	Abar	Cmet	RL	LrT	LrN
	(m)	(m)	(m)		(Hz)	dB(A)	dB(A)	(dB)	(dB)	(dB)	(dB)	(dB)	(dB)	(dB)	(dB)	(dB)	(dB)	dB(A)	dB(A)
1	536311.13	4827978.47	368.65	0	500	82.0	82.0	0.0	0.0	60.2	0.6	-0.4	0.0	0.0	0.0	0.0	-0.0	21.6	21.6

Point Source, ISO 9613, Name: "Agitator 11", ID: "S14"																			
Nr.	X	Y	Z	Refl.	Freq.	LxT	LxN	K0	Dc	Adiv	Aatm	Agr	Afol	Ahous	Abar	Cmet	RL	LrT	LrN
	(m)	(m)	(m)		(Hz)	dB(A)	dB(A)	(dB)	(dB)	(dB)	(dB)	(dB)	(dB)	(dB)	(dB)	(dB)	(dB)	dB(A)	dB(A)
1	536327.35	4828019.36	368.87	0	500	93.0	93.0	0.0	0.0	59.1	0.5	-0.4	0.0	0.0	0.0	0.0	-0.0	33.8	33.8
2	536327.35	4828019.36	368.87	1	500	93.0	93.0	0.0	0.0	59.1	0.5	-0.4	0.0	0.0	0.0	0.0	1.0	32.7	32.7

Point Source, ISO 9613, Name: "Agitator 12", ID: "S15"																			
Nr.	X	Y	Z	Refl.	Freq.	LxT	LxN	K0	Dc	Adiv	Aatm	Agr	Afol	Ahous	Abar	Cmet	RL	LrT	LrN
	(m)	(m)	(m)		(Hz)	dB(A)	dB(A)	(dB)	(dB)	(dB)	(dB)	(dB)	(dB)	(dB)	(dB)	(dB)	(dB)	dB(A)	dB(A)
1	536339.00	4828012.25	368.94	0	500	93.0	93.0	0.0	0.0	59.5	0.5	-0.5	0.0	0.0	9.6	0.0	-0.0	23.9	23.9

Point Source, ISO 9613, Name: "Agitator 13", ID: "S16"																			
Nr.	X	Y	Z	Refl.	Freq.	LxT	LxN	K0	Dc	Adiv	Aatm	Agr	Afol	Ahous	Abar	Cmet	RL	LrT	LrN
	(m)	(m)	(m)		(Hz)	dB(A)	dB(A)	(dB)	(dB)	(dB)	(dB)	(dB)	(dB)	(dB)	(dB)	(dB)	(dB)	dB(A)	dB(A)
1	536350.13	4828005.98	369.22	0	500	93.0	93.0	0.0	0.0	59.8	0.5	-0.5	0.0	0.0	18.3	0.0	-0.0	14.9	14.9

Point Source, ISO 9613, Name: "Agitator 17", ID: "S17"																			
Nr.	X	Y	Z	Refl.	Freq.	LxT	LxN	K0	Dc	Adiv	Aatm	Agr	Afol	Ahous	Abar	Cmet	RL	LrT	LrN
	(m)	(m)	(m)		(Hz)	dB(A)	dB(A)	(dB)	(dB)	(dB)	(dB)	(dB)	(dB)	(dB)	(dB)	(dB)	(dB)	dB(A)	dB(A)
1	536351.78	4828004.07	369.22	0	500	93.0	93.0	0.0	0.0	59.9	0.5	-0.5	0.0	0.0	18.1	0.0	-0.0	14.9	14.9

Point Source, ISO 9613, Name: "Radiator", ID: "S18A"																			
Nr.	X	Y	Z	Refl.	Freq.	LxT	LxN	K0	Dc	Adiv	Aatm	Agr	Afol	Ahous	Abar	Cmet	RL	LrT	LrN
	(m)	(m)	(m)		(Hz)	dB(A)	dB(A)	(dB)	(dB)	(dB)	(dB)	(dB)	(dB)	(dB)	(dB)	(dB)	(dB)	dB(A)	dB(A)
1	536418.39	4828045.06	365.00	0	500	97.0	97.0	0.0	0.0	59.9	0.5	1.5	0.0	0.0	3.3	0.0	-0.0	31.8	31.8

Point Source, ISO 9613, Name: "Radiator", ID: "S18B"																			
Nr.	X	Y	Z	Refl.	Freq.	LxT	LxN	K0	Dc	Adiv	Aatm	Agr	Afol	Ahous	Abar	Cmet	RL	LrT	LrN
	(m)	(m)	(m)		(Hz)	dB(A)	dB(A)	(dB)	(dB)	(dB)	(dB)	(dB)	(dB)	(dB)	(dB)	(dB)	(dB)	dB(A)	dB(A)
1	536424.61	4828044.37	365.00	0	500	97.0	97.0	0.0	0.0	60.0	0.5	1.5	0.0	0.0	3.3	0.0	-0.0	31.7	31.7
2	536424.61	4828044.37	365.00	1	500	97.0	97.0	0.0	0.0	61.4	0.6	-2.0	0.0	0.0	5.4	0.0	1.0	30.6	30.6
3	536424.61	4828044.37	365.00	1	500	97.0	97.0	0.0	0.0	60.1	0.6	1.0	0.0	0.0	3.8	0.0	1.0	30.5	30.5

Point Source, ISO 9613, Name: "Discharge", ID: "S19A"																			
Nr.	X	Y	Z	Refl.	Freq.	LxT	LxN	K0	Dc	Adiv	Aatm	Agr	Afol	Ahous	Abar	Cmet	RL	LrT	LrN
	(m)	(m)	(m)		(Hz)	dB(A)	dB(A)	(dB)	(dB)	(dB)	(dB)	(dB)	(dB)	(dB)	(dB)	(dB)	(dB)	dB(A)	dB(A)
1	536418.68	4828042.44	365.50	0	500	70.6	70.6	0.0	0.0	59.9	0.5	0.3	0.0	0.0	0.0	0.0	-0.0	9.8	9.8
2	536418.68	4828042.44	365.50	1	500	70.6	70.6	0.0	0.0	61.2	0.6	-1.8	0.0	0.0	24.4	0.0	1.0	-14.7	-14.7

Point Source, ISO 9613, Name: "Discharge", ID: "S19B"																			
Nr.	X	Y	Z	Refl.	Freq.	LxT	LxN	K0	Dc	Adiv	Aatm	Agr	Afol	Ahous	Abar	Cmet	RL	LrT	LrN
	(m)	(m)	(m)		(Hz)	dB(A)	dB(A)	(dB)	(dB)	(dB)	(dB)	(dB)	(dB)	(dB)	(dB)	(dB)	(dB)	dB(A)	dB(A)
1	536423.48	4828041.86	365.50	0	500	70.6	70.6	0.0	0.0	60.1	0.6	0.3	0.0	0.0	0.0	0.0	-0.0	9.7	9.7
2	536423.48	4828041.86	365.50	1	500	70.6	70.6	0.0	0.0	61.3	0.6	-1.9	0.0	0.0	24.3	0.0	1.0	-14.8	-14.8

Point Source, ISO 9613, Name: "Intake", ID: "S20A"																			
Nr.	X	Y	Z	Refl.	Freq.	LxT	LxN	K0	Dc	Adiv	Aatm	Agr	Afol	Ahous	Abar	Cmet	RL	LrT	LrN
	(m)	(m)	(m)		(Hz)	dB(A)	dB(A)	(dB)	(dB)	(dB)	(dB)	(dB)	(dB)	(dB)	(dB)	(dB)	(dB)	dB(A)	dB(A)
1	536417.36	4828029.73	369.55	0	500	69.6	69.6	0.0	0.0	60.2	0.6	-0.3	0.0	0.0	0.0	0.0	-0.0	9.1	9.1
2	536417.36	4828029.73	369.55	1	500	69.6	69.6	0.0	0.0	61.2	0.6	-0.8	0.0	0.0	15.4	0.0	1.0	-7.7	-7.7

Point Source, ISO 9613, Name: "Intake", ID: "S20B"																			
Nr.	X	Y	Z	Refl.	Freq.	LxT	LxN	K0	Dc	Adiv	Aatm	Agr	Afol	Ahous	Abar	Cmet	RL	LrT	LrN
	(m)	(m)	(m)		(Hz)	dB(A)	dB(A)	(dB)	(dB)	(dB)	(dB)	(dB)	(dB)	(dB)	(dB)	(dB)	(dB)	dB(A)	dB(A)
1	536422.07	4828029.14	369.55	0	500	69.6	69.6	0.0	0.0	60.3	0.6	-0.3	0.0	0.0	0.0	0.0	-0.0	9.0	9.0
2	536422.07	4828029.14	369.55	1	500	69.6	69.6	0.0	0.0	61.3	0.6	-0.9	0.0	0.0	14.7	0.0	1.0	-7.1	-7.1

Point Source, ISO 9613, Name: "Transformer", ID: "S21"																			
Nr.	X	Y	Z	Refl.	Freq.	LxT	LxN	K0	Dc	Adiv	Aatm	Agr	Afol	Ahous	Abar	Cmet	RL	LrT	LrN
	(m)	(m)	(m)		(Hz)	dB(A)	dB(A)	(dB)	(dB)	(dB)	(dB)	(dB)	(dB)	(dB)	(dB)	(dB)	(dB)	dB(A)	dB(A)
1	536427.50	4828024.94	365.49	0	32	37.6	37.6	0.0	0.0	60.5	0.0	-3.9	0.0	0.0	4.6	0.0	-0.0	-23.6	-23.6
2	536427.50	4828024.94	365.49	0	63	56.8	56.8	0.0	0.0	60.5	0.0	-3.9	0.0	0.0	6.4	0.0	-0.0	-6.3	-6.3
3	536427.50	4828024.94	365.49	0	125	68.9	68.9	0.0	0.0	60.5	0.1	3.3	0.0	0.0	6.8	0.0	-0.0	-1.8	-1.8
4	536427.50	4828024.94	365.49	0	250	71.4	71.4	0.0	0.0	60.5	0.3	3.0	0.0	0.0	10.6	0.0	-0.0	-3.0	-3.0
5	536427.50	4828024.94	365.49	0	500	76.8	76.8	0.0	0.0	60.5	0.6	-0.3	0.0	0.0	15.8	0.0	-0.0	0.2	0.2
6	536427.50	4828024.94	365.49	0	1000	74.0	74.0	0.0	0.0	60.5	1.1	-0.8	0.0	0.0	18.9	0.0	-0.0	-5.8	-5.8
7	536427.50	4828024.94	365.49	0	2000	70.2	70.2	0.0	0.0	60.5	2.9	-0.8	0.0	0.0	21.9	0.0	-0.0	-14.3	-14.3
8	536427.50	4828024.94	365.49	0	4000	65.0	65.0	0.0	0.0	60.5	9.8	-0.8	0.0	0.0	23.2	0.0	-0.0	-27.7	-27.7
9	536427.50	4828024.94	365.49	0	8000	55.9	55.9	0.0	0.0	60.5	35.0	-0.8	0.0	0.0	24.0	0.0	-0.0	-62.8	-62.8
10	536427.50	4828024.94	365.49	1	250	71.4	71.4	0.0	0.0	61.4	0.4	-0.5	0.0	0.0	19.5	0.0	1.0	-10.4	-10.4
11	536427.50	4828024.94	365.49	1	500	76.8	76.8	0.0	0.0	61.4	0.6	-1.9	0.0	0.0	22.6	0.0	1.0	-7.0	-7.0
12	536427.50	4828024.94	365.49	1	1000	74.0	74.0	0.0	0.0	61.4	1.2	-1.9	0.0	0.0	25.0	0.0	1.0	-12.8	-12.8
13	536427.50	4828024.94	365.49	1	2000	70.2	70.2	0.0	0.0	61.4	3.2	-1.9	0.0	0.0	25.0	0.0	1.0	-18.6	-18.6
14	536427.50	4828024.94	365.49	1	4000	65.0	65.0	0.0	0.0	61.4	10.9	-1.9	0.0	0.0	25.0	0.0	1.0	-31.4	-31.4
15	536427.50	4828024.94	365.49	1	8000	55.9	55.9	0.0	0.0	61.4	38.8	-1.9	0.0	0.0	25.0	0.0	1.0	-68.5	-68.5
16	536427.50	4828024.94	365.49	1	4000	65.0	65.0	0.0	0.0	61.0	10.4	-1.6	0.0	0.0	25.0	0.0	1.0	-30.8	-30.8
17	536427.50	4828024.94	365.49	1	8000	55.9	55.9	0.0	0.0	61.0	37.1	-1.6	0.0	0.0	25.0	0.0	1.0	-66.6	-66.6

Point Source, ISO 9613, Name: "Radiator2", ID: "SR"																			
Nr.	X	Y	Z	Refl.	Freq.	LxT	LxN	K0	Dc	Adiv	Aatm	Agr	Afol	Ahous	Abar	Cmet	RL	LrT	LrN
	(m)	(m)	(m)		(Hz)	dB(A)	dB(A)	(dB)	(dB)	(dB)	(dB)	(dB)	(dB)	(dB)	(dB)	(dB)	(dB)	dB(A)	dB(A)
1	536359.28	4828005.67	365.86	0	32	-8.4	-8.4	0.0	0.0	59.9	0.0	-3.9	0.0	0.0	8.7	0.0	-0.0	-73.1	-73.1
2	536359.28	4828005.67	365.86	0	63	4.8	4.8	0.0	0.0	59.9	0.0	-3.9	0.0	0.0	11.5	0.0	-0.0	-62.7	-62.7
3	536359.28	4828005.67	365.86	0	125	14.9	14.9	0.0	0.0	59.9	0.1	1.5	0.0	0.0	13.8	0.0	-0.0	-60.5	-60.5
4	536359.28	4828005.67	365.86	0	250	22.4	22.4	0.0	0.0	59.9	0.3	-0.2	0.0	0.0	18.7	0.0	-0.0	-56.3	-56.3
5	536359.28	4828005.67	365.86	0	500	97.0	97.0	0.0	0.0	59.9	0.5	-1.5	0.0	0.0	22.0	0.0	-0.0	16.1	16.1
6	536359.28	4828005.67	365.86	0	1000	31.0	31.0	0.0	0.0	59.9	1.0	-1.5	0.0	0.0	23.3	0.0	-0.0	-51.7	-51.7
7	536359.28	4828005.67	365.86	0	2000	32.2	32.2	0.0	0.0	59.9	2.7	-1.5	0.0	0.0	24.0	0.0	-0.0	-52.9	-52.9

Point Source, ISO 9613, Name: "Radiator2", ID: "SR"																			
Nr.	X	Y	Z	Refl.	Freq.	LxT	LxN	K0	Dc	Adiv	Aatm	Agr	Afol	Ahous	Abar	Cmet	RL	LrT	LrN
	(m)	(m)	(m)		(Hz)	dB(A)	dB(A)	(dB)	(dB)	(dB)	(dB)	(dB)	(dB)	(dB)	(dB)	(dB)	(dB)	dB(A)	dB(A)
8	536359.28	4828005.67	365.86	0	4000	32.0	32.0	0.0	0.0	59.9	9.2	-1.5	0.0	0.0	24.5	0.0	-0.0	-60.0	-60.0
9	536359.28	4828005.67	365.86	0	8000	29.9	29.9	0.0	0.0	59.9	32.7	-1.5	0.0	0.0	24.7	0.0	-0.0	-85.9	-85.9

Line Source, ISO 9613, Name: "Truck Route", ID: "Truck Route"																			
Nr.	X	Y	Z	Refl.	Freq.	LxT	LxN	K0	Dc	Adiv	Aatm	Agr	Afol	Ahous	Abar	Cmet	RL	LrT	LrN
	(m)	(m)	(m)		(Hz)	dB(A)	dB(A)	(dB)	(dB)	(dB)	(dB)	(dB)	(dB)	(dB)	(dB)	(dB)	(dB)	dB(A)	dB(A)
1	536304.22	4828012.31	363.86	0	500	101.8	91.8	0.0	0.0	59.1	0.5	0.2	0.0	0.0	4.5	0.0	-0.0	37.4	27.4
2	536387.85	4828022.08	365.74	0	500	91.4	81.4	0.0	0.0	59.9	0.5	-0.5	0.0	0.0	0.0	0.0	-0.0	31.6	21.6
3	536385.40	4828014.93	365.46	0	500	91.2	81.2	0.0	0.0	60.0	0.6	-0.8	0.0	0.0	10.4	0.0	-0.0	21.0	11.0
4	536383.35	4828008.93	365.23	0	500	89.8	79.8	0.0	0.0	60.2	0.6	-1.1	0.0	0.0	15.9	0.0	-0.0	14.3	4.3
5	536382.09	4828005.25	365.08	0	500	86.4	76.4	0.0	0.0	60.3	0.6	-1.2	0.0	0.0	17.4	0.0	-0.0	9.4	-0.6
6	536380.59	4828000.89	364.91	0	500	90.8	80.8	0.0	0.0	60.3	0.6	-1.4	0.0	0.0	18.4	0.0	-0.0	12.9	2.9
7	536378.93	4827996.03	364.72	0	500	87.9	77.9	0.0	0.0	60.4	0.6	-1.5	0.0	0.0	19.2	0.0	-0.0	9.2	-0.8
8	536377.45	4827991.69	364.55	0	500	90.1	80.1	0.0	0.0	60.5	0.6	-1.6	0.0	0.0	19.5	0.0	-0.0	11.0	1.0
9	536375.53	4827986.08	364.33	0	500	90.4	80.4	0.0	0.0	60.7	0.6	-1.6	0.0	0.0	19.2	0.0	-0.0	11.6	1.6
10	536372.62	4827977.57	364.00	0	500	93.3	83.3	0.0	0.0	60.8	0.6	-1.7	0.0	0.0	19.5	0.0	-0.0	14.0	4.0
11	536370.05	4827970.05	363.71	0	500	88.6	78.6	0.0	0.0	61.0	0.6	-1.8	0.0	0.0	18.9	0.0	-0.0	9.8	-0.2
12	536367.72	4827963.27	363.44	0	500	92.7	82.7	0.0	0.0	61.1	0.6	-1.9	0.0	0.0	21.6	0.0	-0.0	11.2	1.2
13	536365.85	4827957.78	363.23	0	500	83.6	73.6	0.0	0.0	61.3	0.6	-1.9	0.0	0.0	21.5	0.0	-0.0	2.1	-7.9
14	536365.06	4827955.48	363.14	0	500	88.1	78.1	0.0	0.0	61.3	0.6	-1.9	0.0	0.0	21.4	0.0	-0.0	6.7	-3.3
15	536363.43	4827950.71	362.95	0	500	90.7	80.7	0.0	0.0	61.4	0.6	-2.0	0.0	0.0	20.8	0.0	-0.0	9.8	-0.2
16	536331.80	4828050.22	365.40	0	500	98.2	88.2	0.0	0.0	58.1	0.4	0.5	0.0	0.0	0.0	0.0	-0.0	39.2	29.2
17	536363.89	4828039.60	365.72	0	500	97.5	87.5	0.0	0.0	59.0	0.5	0.1	0.0	0.0	0.0	0.0	-0.0	37.9	27.9
18	536361.28	4827947.41	362.75	0	500	87.8	77.8	0.0	0.0	61.5	0.6	-2.0	0.0	0.0	20.6	0.0	-0.0	7.1	-2.9
19	536358.95	4827947.65	362.71	0	500	83.7	73.7	0.0	0.0	61.4	0.6	-2.0	0.0	0.0	20.6	0.0	-0.0	3.0	-7.0
20	536357.15	4827947.84	362.68	0	500	86.2	76.2	0.0	0.0	61.4	0.6	-2.0	0.0	0.0	20.7	0.0	-0.0	5.4	-4.6
21	536354.86	4827948.08	362.64	0	500	86.1	76.1	0.0	0.0	61.4	0.6	-2.0	0.0	0.0	20.6	0.0	-0.0	5.5	-4.5
22	536351.16	4827948.47	362.58	0	500	89.6	79.6	0.0	0.0	61.4	0.6	-2.0	0.0	0.0	20.3	0.0	-0.0	9.3	-0.7
23	536347.66	4827948.84	362.52	0	500	85.4	75.4	0.0	0.0	61.3	0.6	-2.0	0.0	0.0	18.5	0.0	-0.0	6.9	-3.1
24	536335.74	4827950.10	362.32	0	500	96.0	86.0	0.0	0.0	61.2	0.6	-1.9	0.0	0.0	20.9	0.0	-0.0	15.1	5.1
25	536321.69	4827951.57	362.08	0	500	90.5	80.5	0.0	0.0	61.0	0.6	-1.6	0.0	0.0	16.1	0.0	-0.0	14.4	4.4
26	536383.43	4828028.94	365.97	0	500	93.7	83.7	0.0	0.0	59.6	0.5	-0.3	0.0	0.0	0.0	0.0	-0.0	33.8	23.8
27	536299.61	4827967.09	362.80	0	500	93.6	83.6	0.0	0.0	60.5	0.6	-0.3	0.0	0.0	0.0	0.0	-0.0	32.8	22.8
28	536365.37	4827931.97	362.74	0	500	85.0	75.0	0.0	0.0	61.9	0.7	-2.1	0.0	0.0	18.7	0.0	-0.0	5.8	-4.1
29	536364.10	4827940.04	362.76	0	500	94.2	84.2	0.0	0.0	61.7	0.7	-2.0	0.0	0.0	19.6	0.0	-0.0	14.3	4.3
30	536315.59	4827954.41	362.37	0	500	91.5	81.5	0.0	0.0	60.9	0.6	-1.5	0.0	0.0	9.1	0.0	-0.0	22.4	12.4
31	536311.69	4827957.68	362.81	0	500	86.2	76.2	0.0	0.0	60.8	0.6	-1.3	0.0	0.0	4.8	0.0	-0.0	21.4	11.4
32	536307.59	4827960.68	363.09	0	500	91.5	81.5	0.0	0.0	60.7	0.6	-1.0	0.0	0.0	0.0	0.0	-0.0	31.1	21.1
33	536305.02	4828015.84	363.99	1	500	85.3	75.3	0.0	0.0	59.9	0.5	-1.5	0.0	0.0	14.6	0.0	1.0	10.8	0.8
34	536305.56	4828018.18	364.08	1	500	87.2	77.2	0.0	0.0	59.9	0.5	-1.5	0.0	0.0	14.1	0.0	1.0	13.2	3.1
35	536307.52	4828026.75	364.40	1	500	88.9	78.9	0.0	0.0	59.8	0.5	-1.2	0.0	0.0	10.0	0.0	1.0	18.9	8.9
36	536308.32	4828030.25	364.53	1	500	87.0	77.0	0.0	0.0	59.7	0.5	-1.1	0.0	0.0	9.6	0.0	1.0	17.3	7.3
37	536388.27	4828023.32	365.79	1	500	89.7	79.7	0.0	0.0	60.3	0.6	-1.5	0.0	0.0	24.5	0.0	1.0	4.8	-5.2
38	536387.00	4828019.61	365.64	1	500	86.8	76.8	0.0	0.0	60.3	0.6	-1.4	0.0	0.0	24.3	0.0	1.0	2.0	-8.0
39	536366.25	4828038.32	365.78	1	500	86.5	76.5	0.0	0.0	59.7	0.5	-1.1	0.0	0.0	7.9	0.0	1.0	18.5	8.5
40	536372.56	4828034.92	365.93	1	500	93.3	83.3	0.0	0.0	59.9	0.5	-1.2	0.0	0.0	11.8	0.0	1.0	21.3	11.3
41	536373.39	4828034.47	365.95	1	500	89.4	79.4	0.0	0.0	59.7	0.5	-0.9	0.0	0.0	4.8	0.0	1.0	24.3	14.3
42	536376.65	4828032.71	366.02	1	500	86.5	76.5	0.0	0.0	59.8	0.5	-0.9	0.0	0.0	4.8	0.0	1.0	21.3	11.3
43	536379.00	4828031.42	366.03	1	500	87.1	77.1	0.0	0.0	60.1	0.6	-1.4	0.0	0.0	11.4	0.0	1.0	15.4	5.4
44	536381.34	4828030.11	366.00	1	500	86.5	76.5	0.0	0.0	60.1	0.6	-1.4	0.0	0.0	23.5	0.0	1.0	2.7	-7.3
45	536385.40	4828027.84	365.94	1	500	90.8	80.8	0.0	0.0	60.3	0.6	-1.5	0.0	0.0	25.0	0.0	1.0	5.5	-4.5
46	536388.74	4828025.98	365.89	1	500	81.8	71.8	0.0	0.0	60.3	0.6	-1.5	0.0	0.0	24.8	0.0	1.0	-3.3	-13.3
47	536379.16	4828031.33	366.03	1	500	87.6	77.6	0.0	0.0	59.9	0.5	-1.0	0.0	0.0	4.8	0.0	1.0	22.4	12.4

Configuration	
Parameter	Value
General	
Country	(user defined)
Max. Error (dB)	0.00
Max. Search Radius (m)	2000.00
Min. Dist Src to Rcvr	0.00
Partition	
Raster Factor	0.50
Max. Length of Section (m)	1000.00
Min. Length of Section (m)	1.00
Min. Length of Section (%)	0.00
Proj. Line Sources	On
Proj. Area Sources	On
Ref. Time	
Reference Time Day (min)	960.00
Reference Time Night (min)	480.00
Daytime Penalty (dB)	0.00
Recr. Time Penalty (dB)	0.00
Night-time Penalty (dB)	0.00
DTM	
Standard Height (m)	348.00
Model of Terrain	Triangulation
Reflection	
max. Order of Reflection	1
Search Radius Src	100.00
Search Radius Rcvr	100.00
Max. Distance Source - Rcvr	1000.00 1000.00
Min. Distance Rcvr - Reflector	1.00 1.00
Min. Distance Source - Reflector	0.10
Industrial (ISO 9613)	
Lateral Diffraction	some Obj
Obst. within Area Src do not shield	On
Screening	
	Excl. Ground Att. over Barrier
	Dz with limit (20/25)
Barrier Coefficients C1,2,3	3.0 20.0 0.0
Temperature (°C)	10
rel. Humidity (%)	70
Ground Absorption G	0.00
Wind Speed for Dir. (m/s)	3.0
Roads (???)	
Railways (???)	
Aircraft (???)	
Strictly acc. to AzB	

Receiver

Name: POR 1 - Arthur Street Residence

ID:

X: 536097.09

Y: 4828071.00

Z: 359.89

Point Source, ISO 9613, Name: "Engine # 1", ID: "S1A"

Nr.	X (m)	Y (m)	Z (m)	Refl.	Freq. (Hz)	LxT dB(A)	LxN dB(A)	K0 (dB)	Dc (dB)	Adiv (dB)	Aatm (dB)	Agr (dB)	Afol (dB)	Ahous (dB)	Abar (dB)	Cmet (dB)	RL (dB)	LrT dB(A)	LrN dB(A)
1	536418.76	4828039.34	372.55	0	32	66.6	66.6	0.0	0.0	61.2	0.0	-3.0	0.0	0.0	0.0	0.0	-0.0	8.4	8.4
2	536418.76	4828039.34	372.55	0	63	101.8	101.8	0.0	0.0	61.2	0.0	-3.0	0.0	0.0	0.0	0.0	-0.0	43.6	43.6
3	536418.76	4828039.34	372.55	0	125	109.9	109.9	0.0	0.0	61.2	0.1	2.7	0.0	0.0	0.0	0.0	-0.0	45.9	45.9
4	536418.76	4828039.34	372.55	0	250	115.4	115.4	0.0	0.0	61.2	0.3	0.8	0.0	0.0	0.0	0.0	-0.0	53.1	53.1
5	536418.76	4828039.34	372.55	0	500	115.8	115.8	0.0	0.0	61.2	0.6	-0.6	0.0	0.0	0.0	0.0	-0.0	54.6	54.6
6	536418.76	4828039.34	372.55	0	1000	116.0	116.0	0.0	0.0	61.2	1.2	-0.6	0.0	0.0	0.0	0.0	-0.0	54.2	54.2
7	536418.76	4828039.34	372.55	0	2000	120.2	120.2	0.0	0.0	61.2	3.1	-0.6	0.0	0.0	0.0	0.0	-0.0	56.5	56.5
8	536418.76	4828039.34	372.55	0	4000	121.0	121.0	0.0	0.0	61.2	10.6	-0.6	0.0	0.0	0.0	0.0	-0.0	49.8	49.8
9	536418.76	4828039.34	372.55	0	8000	116.9	116.9	0.0	0.0	61.2	37.8	-0.6	0.0	0.0	0.0	0.0	-0.0	18.5	18.5

Point Source, ISO 9613, Name: "Engine # 2", ID: "S1B"

Nr.	X (m)	Y (m)	Z (m)	Refl.	Freq. (Hz)	LxT dB(A)	LxN dB(A)	K0 (dB)	Dc (dB)	Adiv (dB)	Aatm (dB)	Agr (dB)	Afol (dB)	Ahous (dB)	Abar (dB)	Cmet (dB)	RL (dB)	LrT dB(A)	LrN dB(A)
1	536422.75	4828038.88	372.55	0	32	66.6	66.6	0.0	0.0	61.3	0.0	-3.0	0.0	0.0	0.0	0.0	-0.0	8.3	8.3
2	536422.75	4828038.88	372.55	0	63	101.8	101.8	0.0	0.0	61.3	0.0	-3.0	0.0	0.0	0.0	0.0	-0.0	43.4	43.4
3	536422.75	4828038.88	372.55	0	125	109.9	109.9	0.0	0.0	61.3	0.1	2.7	0.0	0.0	0.0	0.0	-0.0	45.8	45.8
4	536422.75	4828038.88	372.55	0	250	115.4	115.4	0.0	0.0	61.3	0.3	0.8	0.0	0.0	0.0	0.0	-0.0	53.0	53.0
5	536422.75	4828038.88	372.55	0	500	115.8	115.8	0.0	0.0	61.3	0.6	-0.6	0.0	0.0	0.0	0.0	-0.0	54.5	54.5
6	536422.75	4828038.88	372.55	0	1000	116.0	116.0	0.0	0.0	61.3	1.2	-0.6	0.0	0.0	0.0	0.0	-0.0	54.1	54.1
7	536422.75	4828038.88	372.55	0	2000	120.2	120.2	0.0	0.0	61.3	3.2	-0.6	0.0	0.0	0.0	0.0	-0.0	56.4	56.4
8	536422.75	4828038.88	372.55	0	4000	121.0	121.0	0.0	0.0	61.3	10.7	-0.6	0.0	0.0	0.0	0.0	-0.0	49.6	49.6
9	536422.75	4828038.88	372.55	0	8000	116.9	116.9	0.0	0.0	61.3	38.3	-0.6	0.0	0.0	0.0	0.0	-0.0	17.9	17.9

Point Source, ISO 9613, Name: "Biofilter fan", ID: "S2A"

Nr.	X (m)	Y (m)	Z (m)	Refl.	Freq. (Hz)	LxT dB(A)	LxN dB(A)	K0 (dB)	Dc (dB)	Adiv (dB)	Aatm (dB)	Agr (dB)	Afol (dB)	Ahous (dB)	Abar (dB)	Cmet (dB)	RL (dB)	LrT dB(A)	LrN dB(A)
1	536372.00	4828025.02	365.65	0	32	-39.4	-39.4	0.0	0.0	59.9	0.0	-3.9	0.0	0.0	5.4	0.0	-0.0	100.8	100.8
2	536372.00	4828025.02	365.65	0	63	88.8	88.8	0.0	0.0	59.9	0.0	-3.9	0.0	0.0	7.8	0.0	-0.0	24.9	24.9
3	536372.00	4828025.02	365.65	0	125	91.9	91.9	0.0	0.0	59.9	0.1	1.4	0.0	0.0	10.2	0.0	-0.0	20.3	20.3
4	536372.00	4828025.02	365.65	0	250	79.4	79.4	0.0	0.0	59.9	0.3	-0.3	0.0	0.0	13.9	0.0	-0.0	5.6	5.6
5	536372.00	4828025.02	365.65	0	500	83.8	83.8	0.0	0.0	59.9	0.5	-1.6	0.0	0.0	16.8	0.0	-0.0	8.2	8.2
6	536372.00	4828025.02	365.65	0	1000	83.0	83.0	0.0	0.0	59.9	1.0	-1.6	0.0	0.0	19.8	0.0	-0.0	3.9	3.9
7	536372.00	4828025.02	365.65	0	2000	81.2	81.2	0.0	0.0	59.9	2.7	-1.6	0.0	0.0	21.8	0.0	-0.0	-1.6	-1.6
8	536372.00	4828025.02	365.65	0	4000	73.0	73.0	0.0	0.0	59.9	9.1	-1.6	0.0	0.0	23.1	0.0	-0.0	-17.5	-17.5
9	536372.00	4828025.02	365.65	0	8000	62.9	62.9	0.0	0.0	59.9	32.6	-1.6	0.0	0.0	23.9	0.0	-0.0	-51.9	-51.9

Point Source, ISO 9613, Name: "Biofilter fan", ID: "S2B"

Nr.	X (m)	Y (m)	Z (m)	Refl.	Freq. (Hz)	LxT dB(A)	LxN dB(A)	K0 (dB)	Dc (dB)	Adiv (dB)	Aatm (dB)	Agr (dB)	Afol (dB)	Ahous (dB)	Abar (dB)	Cmet (dB)	RL (dB)	LrT dB(A)	LrN dB(A)
1	536373.92	4828028.71	365.66	0	32	-39.4	-39.4	0.0	0.0	59.9	0.0	-3.9	0.0	0.0	4.8	0.0	-0.0	100.2	100.2
2	536373.92	4828028.71	365.66	0	63	88.8	88.8	0.0	0.0	59.9	0.0	-3.9	0.0	0.0	6.1	0.0	-0.0	26.6	26.6
3	536373.92	4828028.71	365.66	0	125	91.9	91.9	0.0	0.0	59.9	0.1	1.4	0.0	0.0	7.1	0.0	-0.0	23.3	23.3
4	536373.92	4828028.71	365.66	0	250	79.4	79.4	0.0	0.0	59.9	0.3	-0.3	0.0	0.0	11.0	0.0	-0.0	8.4	8.4
5	536373.92	4828028.71	365.66	0	500	83.8	83.8	0.0	0.0	59.9	0.5	-1.7	0.0	0.0	14.7	0.0	-0.0	10.3	10.3
6	536373.92	4828028.71	365.66	0	1000	83.0	83.0	0.0	0.0	59.9	1.0	-1.7	0.0	0.0	18.3	0.0	-0.0	5.3	5.3
7	536373.92	4828028.71	365.66	0	2000	81.2	81.2	0.0	0.0	59.9	2.7	-1.7	0.0	0.0	21.7	0.0	-0.0	-1.4	-1.4
8	536373.92	4828028.71	365.66	0	4000	73.0	73.0	0.0	0.0	59.9	9.2	-1.7	0.0	0.0	23.3	0.0	-0.0	-17.7	-17.7
9	536373.92	4828028.71	365.66	0	8000	62.9	62.9	0.0	0.0	59.9	32.7	-1.7	0.0	0.0	24.0	0.0	-0.0	-52.2	-52.2

Point Source, ISO 9613, Name: "Agitator 1", ID: "S4"

Nr.	X (m)	Y (m)	Z (m)	Refl.	Freq. (Hz)	LxT dB(A)	LxN dB(A)	K0 (dB)	Dc (dB)	Adiv (dB)	Aatm (dB)	Agr (dB)	Afol (dB)	Ahous (dB)	Abar (dB)	Cmet (dB)	RL (dB)	LrT dB(A)	LrN dB(A)
1	536331.65	4828009.55	369.56	0	500	82.0	82.0	0.0	0.0	58.7	0.5	-0.3	0.0	0.0	9.1	0.0	-0.0	14.0	14.0

Point Source, ISO 9613, Name: "Agitator 2", ID: "S5"																			
Nr.	X	Y	Z	Refl.	Freq.	LxT	LxN	K0	Dc	Adiv	Aatm	Agr	Afol	Ahous	Abar	Cmet	RL	LrT	LrN
	(m)	(m)	(m)		(Hz)	dB(A)	dB(A)	(dB)	(dB)	(dB)	(dB)	(dB)	(dB)	(dB)	(dB)	(dB)	(dB)	dB(A)	dB(A)
1	536312.63	4827995.86	368.92	0	500	82.0	82.0	0.0	0.0	58.2	0.4	-0.2	0.0	0.0	0.0	0.0	-0.0	23.5	23.5

Point Source, ISO 9613, Name: "Agitator 3", ID: "S6"																			
Nr.	X	Y	Z	Refl.	Freq.	LxT	LxN	K0	Dc	Adiv	Aatm	Agr	Afol	Ahous	Abar	Cmet	RL	LrT	LrN
	(m)	(m)	(m)		(Hz)	dB(A)	dB(A)	(dB)	(dB)	(dB)	(dB)	(dB)	(dB)	(dB)	(dB)	(dB)	(dB)	dB(A)	dB(A)
1	536332.71	4827992.63	369.53	0	500	82.0	82.0	0.0	0.0	58.9	0.5	-0.3	0.0	0.0	0.0	0.0	-0.0	22.9	22.9

Point Source, ISO 9613, Name: "Agitator 4", ID: "S7"																			
Nr.	X	Y	Z	Refl.	Freq.	LxT	LxN	K0	Dc	Adiv	Aatm	Agr	Afol	Ahous	Abar	Cmet	RL	LrT	LrN
	(m)	(m)	(m)		(Hz)	dB(A)	dB(A)	(dB)	(dB)	(dB)	(dB)	(dB)	(dB)	(dB)	(dB)	(dB)	(dB)	dB(A)	dB(A)
1	536342.47	4827997.19	369.23	0	500	82.0	82.0	0.0	0.0	59.2	0.5	-0.4	0.0	0.0	16.3	0.0	-0.0	6.4	6.4

Point Source, ISO 9613, Name: "Agitator 5", ID: "S8"																			
Nr.	X	Y	Z	Refl.	Freq.	LxT	LxN	K0	Dc	Adiv	Aatm	Agr	Afol	Ahous	Abar	Cmet	RL	LrT	LrN
	(m)	(m)	(m)		(Hz)	dB(A)	dB(A)	(dB)	(dB)	(dB)	(dB)	(dB)	(dB)	(dB)	(dB)	(dB)	(dB)	dB(A)	dB(A)
1	536360.09	4827985.34	369.74	0	500	82.0	82.0	0.0	0.0	59.8	0.5	-0.5	0.0	0.0	19.8	0.0	-0.0	2.3	2.3

Point Source, ISO 9613, Name: "Agitator 6", ID: "S9"																			
Nr.	X	Y	Z	Refl.	Freq.	LxT	LxN	K0	Dc	Adiv	Aatm	Agr	Afol	Ahous	Abar	Cmet	RL	LrT	LrN
	(m)	(m)	(m)		(Hz)	dB(A)	dB(A)	(dB)	(dB)	(dB)	(dB)	(dB)	(dB)	(dB)	(dB)	(dB)	(dB)	dB(A)	dB(A)
1	536342.19	4827976.06	369.87	0	500	82.0	82.0	0.0	0.0	59.4	0.5	-0.4	0.0	0.0	11.0	0.0	-0.0	11.5	11.5

Point Source, ISO 9613, Name: "Agitator 7", ID: "S10"																			
Nr.	X	Y	Z	Refl.	Freq.	LxT	LxN	K0	Dc	Adiv	Aatm	Agr	Afol	Ahous	Abar	Cmet	RL	LrT	LrN
	(m)	(m)	(m)		(Hz)	dB(A)	dB(A)	(dB)	(dB)	(dB)	(dB)	(dB)	(dB)	(dB)	(dB)	(dB)	(dB)	dB(A)	dB(A)
1	536327.57	4827985.16	368.45	0	500	82.0	82.0	0.0	0.0	58.8	0.5	-0.3	0.0	0.0	0.0	0.0	-0.0	23.0	23.0

Point Source, ISO 9613, Name: "Agitator 8", ID: "S11"																			
Nr.	X	Y	Z	Refl.	Freq.	LxT	LxN	K0	Dc	Adiv	Aatm	Agr	Afol	Ahous	Abar	Cmet	RL	LrT	LrN
	(m)	(m)	(m)		(Hz)	dB(A)	dB(A)	(dB)	(dB)	(dB)	(dB)	(dB)	(dB)	(dB)	(dB)	(dB)	(dB)	dB(A)	dB(A)
1	536336.44	4827966.69	368.58	0	500	82.0	82.0	0.0	0.0	59.3	0.5	-0.4	0.0	0.0	19.5	0.0	-0.0	3.0	3.0

Point Source, ISO 9613, Name: "Agitator 9", ID: "S12"																			
Nr.	X	Y	Z	Refl.	Freq.	LxT	LxN	K0	Dc	Adiv	Aatm	Agr	Afol	Ahous	Abar	Cmet	RL	LrT	LrN
	(m)	(m)	(m)		(Hz)	dB(A)	dB(A)	(dB)	(dB)	(dB)	(dB)	(dB)	(dB)	(dB)	(dB)	(dB)	(dB)	dB(A)	dB(A)
1	536317.58	4827959.11	367.79	0	500	82.0	82.0	0.0	0.0	58.9	0.5	-0.3	0.0	0.0	4.7	0.0	-0.0	18.2	18.2

Point Source, ISO 9613, Name: "Agitator 10", ID: "S13"																			
Nr.	X	Y	Z	Refl.	Freq.	LxT	LxN	K0	Dc	Adiv	Aatm	Agr	Afol	Ahous	Abar	Cmet	RL	LrT	LrN
	(m)	(m)	(m)		(Hz)	dB(A)	dB(A)	(dB)	(dB)	(dB)	(dB)	(dB)	(dB)	(dB)	(dB)	(dB)	(dB)	dB(A)	dB(A)
1	536311.13	4827978.47	368.65	0	500	82.0	82.0	0.0	0.0	58.4	0.5	-0.2	0.0	0.0	0.0	0.0	-0.0	23.4	23.4

Point Source, ISO 9613, Name: "Agitator 11", ID: "S14"																			
Nr.	X	Y	Z	Refl.	Freq.	LxT	LxN	K0	Dc	Adiv	Aatm	Agr	Afol	Ahous	Abar	Cmet	RL	LrT	LrN
	(m)	(m)	(m)		(Hz)	dB(A)	dB(A)	(dB)	(dB)	(dB)	(dB)	(dB)	(dB)	(dB)	(dB)	(dB)	(dB)	dB(A)	dB(A)
1	536327.35	4828019.36	368.87	0	500	93.0	93.0	0.0	0.0	58.5	0.5	-0.3	0.0	0.0	0.0	0.0	-0.0	34.3	34.3

Point Source, ISO 9613, Name: "Agitator 12", ID: "S15"																			
Nr.	X	Y	Z	Refl.	Freq.	LxT	LxN	K0	Dc	Adiv	Aatm	Agr	Afol	Ahous	Abar	Cmet	RL	LrT	LrN
	(m)	(m)	(m)		(Hz)	dB(A)	dB(A)	(dB)	(dB)	(dB)	(dB)	(dB)	(dB)	(dB)	(dB)	(dB)	(dB)	dB(A)	dB(A)
1	536339.00	4828012.25	368.94	0	500	93.0	93.0	0.0	0.0	58.9	0.5	-0.4	0.0	0.0	2.1	0.0	-0.0	31.9	31.9
2	536339.00	4828012.25	368.94	1	500	93.0	93.0	0.0	0.0	58.9	0.5	-0.4	0.0	0.0	4.8	0.0	1.0	28.2	28.2

Point Source, ISO 9613, Name: "Agitator 13", ID: "S16"																			
Nr.	X	Y	Z	Refl.	Freq.	LxT	LxN	K0	Dc	Adiv	Aatm	Agr	Afol	Ahous	Abar	Cmet	RL	LrT	LrN
	(m)	(m)	(m)		(Hz)	dB(A)	dB(A)	(dB)	(dB)	(dB)	(dB)	(dB)	(dB)	(dB)	(dB)	(dB)	(dB)	dB(A)	dB(A)
1	536350.13	4828005.98	369.22	0	500	93.0	93.0	0.0	0.0	59.3	0.5	-0.5	0.0	0.0	4.3	0.0	-0.0	29.2	29.2

Point Source, ISO 9613, Name: "Agitator 17", ID: "S17"																			
Nr.	X	Y	Z	Refl.	Freq.	LxT	LxN	K0	Dc	Adiv	Aatm	Agr	Afol	Ahous	Abar	Cmet	RL	LrT	LrN
	(m)	(m)	(m)		(Hz)	dB(A)	dB(A)	(dB)	(dB)	(dB)	(dB)	(dB)	(dB)	(dB)	(dB)	(dB)	(dB)	dB(A)	dB(A)
1	536351.78	4828004.07	369.22	0	500	93.0	93.0	0.0	0.0	59.4	0.5	-0.4	0.0	0.0	16.6	0.0	-0.0	16.8	16.8
2	536351.78	4828004.07	369.22	1	500	93.0	93.0	0.0	0.0	59.4	0.5	-0.4	0.0	0.0	4.8	0.0	1.0	27.7	27.7

Point Source, ISO 9613, Name: "Radiator", ID: "S18A"																			
Nr.	X	Y	Z	Refl.	Freq.	LxT	LxN	K0	Dc	Adiv	Aatm	Agr	Afol	Ahous	Abar	Cmet	RL	LrT	LrN
	(m)	(m)	(m)		(Hz)	dB(A)	dB(A)	(dB)	(dB)	(dB)	(dB)	(dB)	(dB)	(dB)	(dB)	(dB)	(dB)	dB(A)	dB(A)
1	536418.39	4828045.06	365.00	0	500	97.0	97.0	0.0	0.0	61.2	0.6	-2.0	0.0	0.0	4.8	0.0	-0.0	32.4	32.4

Point Source, ISO 9613, Name: "Radiator", ID: "S18B"																			
Nr.	X	Y	Z	Refl.	Freq.	LxT	LxN	K0	Dc	Adiv	Aatm	Agr	Afol	Ahous	Abar	Cmet	RL	LrT	LrN
	(m)	(m)	(m)		(Hz)	dB(A)	dB(A)	(dB)	(dB)	(dB)	(dB)	(dB)	(dB)	(dB)	(dB)	(dB)	(dB)	dB(A)	dB(A)
1	536424.61	4828044.37	365.00	0	500	97.0	97.0	0.0	0.0	61.3	0.6	-2.1	0.0	0.0	4.8	0.0	-0.0	32.3	32.3

Point Source, ISO 9613, Name: "Discharge", ID: "S19A"																			
Nr.	X	Y	Z	Refl.	Freq.	LxT	LxN	K0	Dc	Adiv	Aatm	Agr	Afol	Ahous	Abar	Cmet	RL	LrT	LrN
	(m)	(m)	(m)		(Hz)	dB(A)	dB(A)	(dB)	(dB)	(dB)	(dB)	(dB)	(dB)	(dB)	(dB)	(dB)	(dB)	dB(A)	dB(A)
1	536418.68	4828042.44	365.50	0	500	102.6	102.6	0.0	0.0	61.2	0.6	-1.9	0.0	0.0	5.0	0.0	-0.0	37.7	37.7

Point Source, ISO 9613, Name: "Discharge", ID: "S19B"																			
Nr.	X	Y	Z	Refl.	Freq.	LxT	LxN	K0	Dc	Adiv	Aatm	Agr	Afol	Ahous	Abar	Cmet	RL	LrT	LrN
	(m)	(m)	(m)		(Hz)	dB(A)	dB(A)	(dB)	(dB)	(dB)	(dB)	(dB)	(dB)	(dB)	(dB)	(dB)	(dB)	dB(A)	dB(A)
1	536423.48	4828041.86	365.50	0	500	102.6	102.6	0.0	0.0	61.3	0.6	-1.9	0.0	0.0	5.1	0.0	-0.0	37.5	37.5

Point Source, ISO 9613, Name: "Intake", ID: "S20A"																			
Nr.	X	Y	Z	Refl.	Freq.	LxT	LxN	K0	Dc	Adiv	Aatm	Agr	Afol	Ahous	Abar	Cmet	RL	LrT	LrN
	(m)	(m)	(m)		(Hz)	dB(A)	dB(A)	(dB)	(dB)	(dB)	(dB)	(dB)	(dB)	(dB)	(dB)	(dB)	(dB)	dB(A)	dB(A)
1	536417.36	4828029.73	369.55	0	500	102.6	102.6	0.0	0.0	61.2	0.6	-0.9	0.0	0.0	0.0	0.0	-0.0	41.8	41.8

Point Source, ISO 9613, Name: "Intake", ID: "S20B"																			
Nr.	X	Y	Z	Refl.	Freq.	LxT	LxN	K0	Dc	Adiv	Aatm	Agr	Afol	Ahous	Abar	Cmet	RL	LrT	LrN
	(m)	(m)	(m)		(Hz)	dB(A)	dB(A)	(dB)	(dB)	(dB)	(dB)	(dB)	(dB)	(dB)	(dB)	(dB)	(dB)	dB(A)	dB(A)
1	536422.07	4828029.14	369.55	0	500	102.6	102.6	0.0	0.0	61.3	0.6	-1.0	0.0	0.0	0.0	0.0	-0.0	41.6	41.6

Point Source, ISO 9613, Name: "Transformer", ID: "S21"																			
Nr.	X	Y	Z	Refl.	Freq.	LxT	LxN	K0	Dc	Adiv	Aatm	Agr	Afol	Ahous	Abar	Cmet	RL	LrT	LrN
	(m)	(m)	(m)		(Hz)	dB(A)	dB(A)	(dB)	(dB)	(dB)	(dB)	(dB)	(dB)	(dB)	(dB)	(dB)	(dB)	dB(A)	dB(A)
1	536427.50	4828024.94	365.49	0	32	37.6	37.6	0.0	0.0	61.5	0.0	-4.1	0.0	0.0	6.5	0.0	-0.0	-26.3	-26.3
2	536427.50	4828024.94	365.49	0	63	56.8	56.8	0.0	0.0	61.5	0.0	-4.1	0.0	0.0	8.4	0.0	-0.0	-9.0	-9.0
3	536427.50	4828024.94	365.49	0	125	68.9	68.9	0.0	0.0	61.5	0.1	1.2	0.0	0.0	10.1	0.0	-0.0	-3.9	-3.9
4	536427.50	4828024.94	365.49	0	250	71.4	71.4	0.0	0.0	61.5	0.4	-0.6	0.0	0.0	14.9	0.0	-0.0	-4.7	-4.7
5	536427.50	4828024.94	365.49	0	500	76.8	76.8	0.0	0.0	61.5	0.6	-2.0	0.0	0.0	18.8	0.0	-0.0	-2.1	-2.1
6	536427.50	4828024.94	365.49	0	1000	74.0	74.0	0.0	0.0	61.5	1.2	-2.0	0.0	0.0	22.2	0.0	-0.0	-8.9	-8.9
7	536427.50	4828024.94	365.49	0	2000	70.2	70.2	0.0	0.0	61.5	3.2	-2.0	0.0	0.0	24.2	0.0	-0.0	-16.7	-16.7
8	536427.50	4828024.94	365.49	0	4000	65.0	65.0	0.0	0.0	61.5	10.9	-2.0	0.0	0.0	24.6	0.0	-0.0	-30.0	-30.0
9	536427.50	4828024.94	365.49	0	8000	55.9	55.9	0.0	0.0	61.5	39.0	-2.0	0.0	0.0	24.8	0.0	-0.0	-67.3	-67.3

Point Source, ISO 9613, Name: "Radiator2", ID: "SR"																			
Nr.	X	Y	Z	Refl.	Freq.	LxT	LxN	K0	Dc	Adiv	Aatm	Agr	Afol	Ahous	Abar	Cmet	RL	LrT	LrN
	(m)	(m)	(m)		(Hz)	dB(A)	dB(A)	(dB)	(dB)	(dB)	(dB)	(dB)	(dB)	(dB)	(dB)	(dB)	(dB)	dB(A)	dB(A)
1	536359.28	4828005.67	365.86	0	32	-8.4	-8.4	0.0	0.0	59.6	0.0	-3.8	0.0	0.0	6.7	0.0	-0.0	-70.9	-70.9
2	536359.28	4828005.67	365.86	0	63	4.8	4.8	0.0	0.0	59.6	0.0	-3.8	0.0	0.0	8.1	0.0	-0.0	-59.1	-59.1
3	536359.28	4828005.67	365.86	0	125	14.9	14.9	0.0	0.0	59.6	0.1	1.5	0.0	0.0	9.0	0.0	-0.0	-55.4	-55.4
4	536359.28	4828005.67	365.86	0	250	22.4	22.4	0.0	0.0	59.6	0.3	-0.2	0.0	0.0	14.2	0.0	-0.0	-51.6	-51.6
5	536359.28	4828005.67	365.86	0	500	97.0	97.0	0.0	0.0	59.6	0.5	-1.6	0.0	0.0	18.2	0.0	-0.0	20.2	20.2
6	536359.28	4828005.67	365.86	0	1000	31.0	31.0	0.0	0.0	59.6	1.0	-1.6	0.0	0.0	21.7	0.0	-0.0	-49.8	-49.8
7	536359.28	4828005.67	365.86	0	2000	32.2	32.2	0.0	0.0	59.6	2.6	-1.6	0.0	0.0	24.8	0.0	-0.0	-53.3	-53.3
8	536359.28	4828005.67	365.86	0	4000	32.0	32.0	0.0	0.0	59.6	8.9	-1.6	0.0	0.0	25.0	0.0	-0.0	-59.9	-59.9
9	536359.28	4828005.67	365.86	0	8000	29.9	29.9	0.0	0.0	59.6	31.6	-1.6	0.0	0.0	25.0	0.0	-0.0	-84.8	-84.8
10	536359.28	4828005.67	365.86	1	250	22.4	22.4	0.0	0.0	59.7	0.3	-0.2	0.0	0.0	13.1	0.0	1.0	-51.4	-51.4
11	536359.28	4828005.67	365.86	1	500	97.0	97.0	0.0	0.0	59.7	0.5	-1.6	0.0	0.0	16.3	0.0	1.0	21.1	21.1
12	536359.28	4828005.67	365.86	1	1000	31.0	31.0	0.0	0.0	59.7	1.0	-1.6	0.0	0.0	19.3	0.0	1.0	-48.4	-48.4
13	536359.28	4828005.67	365.86	1	2000	32.2	32.2	0.0	0.0	59.7	2.6	-1.6	0.0	0.0	22.3	0.0	1.0	-51.8	-51.8
14	536359.28	4828005.67	365.86	1	4000	32.0	32.0	0.0	0.0	59.7	8.9	-1.6	0.0	0.0	25.0	0.0	1.0	-61.0	-61.0
15	536359.28	4828005.67	365.86	1	8000	29.9	29.9	0.0	0.0	59.7	31.8	-1.6	0.0	0.0	25.0	0.0	1.0	-86.0	-86.0
16	536359.28	4828005.67	365.86	1	250	22.4	22.4	0.0	0.0	59.8	0.3	-0.2	0.0	0.0	14.6	0.0	1.0	-53.1	-53.1
17	536359.28	4828005.67	365.86	1	500	97.0	97.0	0.0	0.0	59.8	0.5	-1.6	0.0	0.0	17.7	0.0	1.0	19.6	19.6
18	536359.28	4828005.67	365.86	1	1000	31.0	31.0	0.0	0.0	59.8	1.0	-1.6	0.0	0.0	20.7	0.0	1.0	-49.9	-49.9
19	536359.28	4828005.67	365.86	1	2000	32.2	32.2	0.0	0.0	59.8	2.7	-1.6	0.0	0.0	23.7	0.0	1.0	-53.3	-53.3
20	536359.28	4828005.67	365.86	1	4000	32.0	32.0	0.0	0.0	59.8	9.0	-1.6	0.0	0.0	25.0	0.0	1.0	-61.2	-61.2
21	536359.28	4828005.67	365.86	1	8000	29.9	29.9	0.0	0.0	59.8	32.1	-1.6	0.0	0.0	25.0	0.0	1.0	-86.4	-86.4

Line Source, ISO 9613, Name: "Truck Route", ID: "Truck Route"																			
Nr.	X	Y	Z	Refl.	Freq.	LxT	LxN	K0	Dc	Adiv	Aatm	Agr	Afol	Ahous	Abar	Cmet	RL	LrT	LrN
	(m)	(m)	(m)		(Hz)	dB(A)	dB(A)	(dB)	(dB)	(dB)	(dB)	(dB)	(dB)	(dB)	(dB)	(dB)	(dB)	dB(A)	dB(A)
1	536304.22	4828012.31	363.86	0	500	101.8	91.8	0.0	0.0	57.7	0.4	0.7	0.0	0.0	0.0	0.0	-0.0	43.0	33.0
2	536388.67	4828024.49	365.83	0	500	86.9	76.9	0.0	0.0	60.4	0.6	-1.7	0.0	0.0	16.6	0.0	-0.0	10.9	0.9
3	536387.99	4828022.49	365.76	0	500	84.3	74.3	0.0	0.0	60.4	0.6	-1.7	0.0	0.0	16.1	0.0	-0.0	8.9	-1.1
4	536387.51	4828021.10	365.70	0	500	84.1	74.1	0.0	0.0	60.4	0.6	-1.7	0.0	0.0	15.9	0.0	-0.0	8.9	-1.1
5	536386.56	4828018.32	365.59	0	500	89.0	79.0	0.0	0.0	60.4	0.6	-1.7	0.0	0.0	17.5	0.0	-0.0	12.3	2.3
6	536385.15	4828014.20	365.43	0	500	88.8	78.8	0.0	0.0	60.4	0.6	-1.7	0.0	0.0	19.1	0.0	-0.0	10.4	0.4
7	536384.29	4828011.68	365.33	0	500	83.0	73.0	0.0	0.0	60.3	0.6	-1.7	0.0	0.0	18.8	0.0	-0.0	5.0	-5.0
8	536383.43	4828009.18	365.24	0	500	88.7	78.7	0.0	0.0	60.3	0.6	-1.7	0.0	0.0	20.4	0.0	-0.0	9.1	-0.9
9	536381.95	4828004.85	365.07	0	500	89.5	79.5	0.0	0.0	60.3	0.6	-1.7	0.0	0.0	16.7	0.0	-0.0	13.6	3.6
10	536380.94	4828001.89	364.95	0	500	83.5	73.5	0.0	0.0	60.3	0.6	-1.7	0.0	0.0	16.8	0.0	-0.0	7.5	-2.5
11	536380.33	4828000.10	364.88	0	500	86.6	76.6	0.0	0.0	60.3	0.6	-1.7	0.0	0.0	12.5	0.0	-0.0	14.9	4.8
12	536379.51	4827997.71	364.79	0	500	86.5	76.5	0.0	0.0	60.3	0.6	-1.7	0.0	0.0	19.1	0.0	-0.0	8.2	-1.8
13	536378.50	4827994.75	364.67	0	500	88.2	78.2	0.0	0.0	60.3	0.6	-1.6	0.0	0.0	19.7	0.0	-0.0	9.4	-0.7
14	536377.51	4827991.86	364.56	0	500	86.3	76.3	0.0	0.0	60.3	0.6	-1.6	0.0	0.0	19.4	0.0	-0.0	7.7	-2.3
15	536373.68	4827980.68	364.12	0	500	95.8	85.8	0.0	0.0	60.3	0.6	-1.6	0.0	0.0	17.9	0.0	-0.0	18.7	8.7
16	536370.04	4827970.03	363.71	0	500	83.5	73.5	0.0	0.0	60.3	0.6	-1.6	0.0	0.0	19.8	0.0	-0.0	4.5	-5.5
17	536369.21	4827967.62	363.61	0	500	88.4	78.4	0.0	0.0	60.3	0.6	-1.6	0.0	0.0	19.8	0.0	-0.0	9.3	-0.7
18	536365.48	4827956.72	363.19	0	500	95.4	85.4	0.0	0.0	60.3	0.6	-1.6	0.0	0.0	14.9	0.0	-0.0	21.2	11.2
19	536331.80	4828050.22	365.40	0	500	98.2	88.2	0.0	0.0	58.4	0.5	-0.0	0.0	0.0	0.0	0.0	-0.0	39.3	29.3
20	536349.04	4827948.70	362.54	0	500	97.0	87.0	0.0	0.0	59.9	0.5	-1.4	0.0	0.0	10.7	0.0	-0.0	27.1	17.1
21	536326.86	4827951.03	362.17	0	500	94.7	84.7	0.0	0.0	59.3	0.5	-0.6	0.0	0.0	0.0	0.0	-0.0	35.5	25.6
22	536357.12	4828043.25	365.57	0	500	94.6	84.6	0.0	0.0	59.3	0.5	-0.9	0.0	0.0	4.8	0.0	-0.0	30.9	20.9
23	536365.07	4828038.96	365.75	0	500	85.4	75.4	0.0	0.0	59.6	0.5	-1.2	0.0	0.0	4.8	0.0	-0.0	21.7	11.7
24	536370.13	4828036.23	365.87	0	500	92.3	82.3	0.0	0.0	59.8	0.5	-1.4	0.0	0.0	4.8	0.0	-0.0	28.7	18.7
25	536376.05	4828033.03	366.01	0	500	88.4	78.4	0.0	0.0	60.0	0.5	-1.5	0.0	0.0	4.8	0.0	-0.0	24.6	14.6
26	536299.61	4827967.09	362.80	0	500	93.6	83.6	0.0	0.0	58.1	0.4	0.5	0.0	0.0	0.0	0.0	-0.0	34.5	24.5
27	536365.20	4827933.08	362.74	0	500	88.5	78.5	0.0	0.0	60.6	0.6	-1.7	0.0	0.0	0.0	0.0	-0.0	29.0	19.0
28	536363.93	4827941.14	362.77	0	500	93.4	83.4	0.0	0.0	60.4	0.6	-1.6	0.0	0.0	9.2	0.0	-0.0	24.8	14.8
29	536314.70	4827955.16	362.47	0	500	92.6	82.6	0.0	0.0	58.8	0.5	-0.1	0.0	0.0	0.0	0.0	-0.0	33.4	23.4
30	536379.45	4828031.17	366.02	0	500	88.4	78.4	0.0	0.0	60.1	0.6	-1.6	0.0	0.0	4.8	0.0	-0.0	24.6	14.6
31	536381.81	4828029.84	365.99	0	500	84.4	74.4	0.0	0.0	60.2	0.6	-1.6	0.0	0.0	7.1	0.0	-0.0	18.1	8.1
32	536383.76	4828028.76	365.96	0	500	87.2	77.2	0.0	0.0	60.2	0.6	-1.6	0.0	0.0	10.9	0.0	-0.0	17.1	7.1
33	536385.59	4828027.74	365.94	0	500	83.5	73.5	0.0	0.0	60.3	0.6	-1.7	0.0	0.0	15.2	0.0	-0.0	9.1	-0.9
34	536387.55	4828026.64	365.91	0	500	87.6	77.6	0.0	0.0	60.4	0.6	-1.7	0.0	0.0	15.6	0.0	-0.0	12.7	2.7
35	536389.03	4828025.81	365.88	0	500	74.9	64.9	0.0	0.0	60.4	0.6	-1.7	0.0	0.0	15.9	0.0	-0.0	-0.3	-10.3
36	536307.59	4827960.68	363.09	0	500	91.5	81.5	0.0	0.0	58.5	0.5	0.2	0.0	0.0	0.0	0.0	-0.0	32.3	22.3
37	536310.76	4828040.95	364.93	1	500	90.1	80.1	0.0	0.0	59.4	0.5	-1.1	0.0	0.0	12.3	0.0	1.0	17.9	7.9
38	536313.45	4828052.74	365.38	1	500	83.6	73.6	0.0	0.0	59.7	0.5	-1.3	0.0	0.0	9.0	0.0	1.0	14.8	4.8
39	536387.31	4828020.52	365.68	1	500	85.1	75.1	0.0	0.0	61.8	0.7	-2.1	0.0	0.0	13.1	0.0	1.0	10.7	0.7
40	536386.74	4828018.86	365.61	1	500	84.9	74.9	0.0	0.0	61.8	0.7	-2.1	0.0	0.0	13.4	0.0	1.0	10.1	0.1
41	536377.79	4827992.70	364.59	1	500	83.1	73.1	0.0	0.0	60.4	0.6	-1.7	0.0	0.0	13.0	0.0	1.0	9.8	-0.3
42	536377.42	4827991.60	364.55	1	500	83.4	73.4	0.0	0.0	60.4	0.6	-1.7	0.0	0.0	13.1	0.0	1.0	10.0	0.0
43	536378.01	4827993.33	364.62	1	500	90.3	80.3	0.0	0.0	60.4	0.6	-1.7	0.0	0.0	17.4	0.0	1.0	12.7	2.6
44	536376.74	4827989.62	364.47	1	500	85.0	75.0	0.0	0.0	60.5	0.6	-1.7	0.0	0.0	15.3	0.0	1.0	9.4	-0.6
45	536375.60	4827986.30	364.34	1	500	89.7	79.7	0.0	0.0	60.5	0.6	-1.7	0.0	0.0	15.7	0.0	1.0	13.6	3.6
46	536340.06	4828048.80	365.40	1	500	81.3	71.3	0.0	0.0	59.8	0.5	-1.4	0.0	0.0	4.8	0.0	1.0	16.6	6.6
47	536318.96	4828052.44	365.40	1	500	92.9	82.9	0.0	0.0	59.5	0.5	-1.2	0.0	0.0	4.8	0.0	1.0	28.2	18.2
48	536386.56	4828027.20	365.92	1	500	87.5	77.5	0.0	0.0	61.8	0.7	-2.1	0.0	0.0	9.1	0.0	1.0	17.0	7.0

Receiver

Name: POR 2 - High Street Residence

ID:

X: 536400.79

Y: 4827726.67

Z: 360.35

Point Source, ISO 9613, Name: "Engine # 1", ID: "S1A"

Nr.	X (m)	Y (m)	Z (m)	Refl.	Freq. (Hz)	LxT dB(A)	LxN dB(A)	K0 (dB)	Dc (dB)	Adiv (dB)	Aatm (dB)	Agr (dB)	Afol (dB)	Ahous (dB)	Abar (dB)	Cmet (dB)	RL (dB)	LrT dB(A)	LrN dB(A)
1	536418.76	4828039.34	372.55	0	32	66.6	66.6	0.0	0.0	60.9	0.0	-3.0	0.0	0.0	0.0	0.0	-0.0	8.7	8.7
2	536418.76	4828039.34	372.55	0	63	101.8	101.8	0.0	0.0	60.9	0.0	-3.0	0.0	0.0	0.0	0.0	-0.0	43.8	43.8
3	536418.76	4828039.34	372.55	0	125	109.9	109.9	0.0	0.0	60.9	0.1	2.6	0.0	0.0	0.0	0.0	-0.0	46.3	46.3
4	536418.76	4828039.34	372.55	0	250	115.4	115.4	0.0	0.0	60.9	0.3	0.7	0.0	0.0	0.0	0.0	-0.0	53.4	53.4
5	536418.76	4828039.34	372.55	0	500	115.8	115.8	0.0	0.0	60.9	0.6	-0.7	0.0	0.0	0.0	0.0	-0.0	54.9	54.9
6	536418.76	4828039.34	372.55	0	1000	116.0	116.0	0.0	0.0	60.9	1.2	-0.7	0.0	0.0	0.0	0.0	-0.0	54.6	54.6
7	536418.76	4828039.34	372.55	0	2000	120.2	120.2	0.0	0.0	60.9	3.0	-0.7	0.0	0.0	0.0	0.0	-0.0	56.9	56.9
8	536418.76	4828039.34	372.55	0	4000	121.0	121.0	0.0	0.0	60.9	10.3	-0.7	0.0	0.0	0.0	0.0	-0.0	50.5	50.5
9	536418.76	4828039.34	372.55	0	8000	116.9	116.9	0.0	0.0	60.9	36.6	-0.7	0.0	0.0	0.0	0.0	-0.0	20.0	20.0

Point Source, ISO 9613, Name: "Engine # 2", ID: "S1B"

Nr.	X (m)	Y (m)	Z (m)	Refl.	Freq. (Hz)	LxT dB(A)	LxN dB(A)	K0 (dB)	Dc (dB)	Adiv (dB)	Aatm (dB)	Agr (dB)	Afol (dB)	Ahous (dB)	Abar (dB)	Cmet (dB)	RL (dB)	LrT dB(A)	LrN dB(A)
1	536422.75	4828038.88	372.55	0	32	66.6	66.6	0.0	0.0	60.9	0.0	-3.0	0.0	0.0	0.0	0.0	-0.0	8.7	8.7
2	536422.75	4828038.88	372.55	0	63	101.8	101.8	0.0	0.0	60.9	0.0	-3.0	0.0	0.0	0.0	0.0	-0.0	43.8	43.8
3	536422.75	4828038.88	372.55	0	125	109.9	109.9	0.0	0.0	60.9	0.1	2.6	0.0	0.0	0.0	0.0	-0.0	46.3	46.3
4	536422.75	4828038.88	372.55	0	250	115.4	115.4	0.0	0.0	60.9	0.3	0.7	0.0	0.0	0.0	0.0	-0.0	53.4	53.4
5	536422.75	4828038.88	372.55	0	500	115.8	115.8	0.0	0.0	60.9	0.6	-0.7	0.0	0.0	0.0	0.0	-0.0	55.0	55.0
6	536422.75	4828038.88	372.55	0	1000	116.0	116.0	0.0	0.0	60.9	1.2	-0.7	0.0	0.0	0.0	0.0	-0.0	54.6	54.6
7	536422.75	4828038.88	372.55	0	2000	120.2	120.2	0.0	0.0	60.9	3.0	-0.7	0.0	0.0	0.0	0.0	-0.0	56.9	56.9
8	536422.75	4828038.88	372.55	0	4000	121.0	121.0	0.0	0.0	60.9	10.3	-0.7	0.0	0.0	0.0	0.0	-0.0	50.5	50.5
9	536422.75	4828038.88	372.55	0	8000	116.9	116.9	0.0	0.0	60.9	36.6	-0.7	0.0	0.0	0.0	0.0	-0.0	20.1	20.1

Point Source, ISO 9613, Name: "Biofilter fan", ID: "S2A"

Nr.	X (m)	Y (m)	Z (m)	Refl.	Freq. (Hz)	LxT dB(A)	LxN dB(A)	K0 (dB)	Dc (dB)	Adiv (dB)	Aatm (dB)	Agr (dB)	Afol (dB)	Ahous (dB)	Abar (dB)	Cmet (dB)	RL (dB)	LrT dB(A)	LrN dB(A)
1	536372.00	4828025.02	365.65	0	32	-39.4	-39.4	0.0	0.0	60.5	0.0	-4.0	0.0	0.0	6.2	0.0	-0.0	102.1	102.1
2	536372.00	4828025.02	365.65	0	63	88.8	88.8	0.0	0.0	60.5	0.0	-4.0	0.0	0.0	8.1	0.0	-0.0	24.2	24.2
3	536372.00	4828025.02	365.65	0	125	91.9	91.9	0.0	0.0	60.5	0.1	1.0	0.0	0.0	10.1	0.0	-0.0	20.1	20.1
4	536372.00	4828025.02	365.65	0	250	79.4	79.4	0.0	0.0	60.5	0.3	-0.7	0.0	0.0	12.9	0.0	-0.0	6.3	6.3
5	536372.00	4828025.02	365.65	0	500	83.8	83.8	0.0	0.0	60.5	0.6	-2.1	0.0	0.0	15.7	0.0	-0.0	9.1	9.1
6	536372.00	4828025.02	365.65	0	1000	83.0	83.0	0.0	0.0	60.5	1.1	-2.1	0.0	0.0	18.1	0.0	-0.0	5.3	5.3
7	536372.00	4828025.02	365.65	0	2000	81.2	81.2	0.0	0.0	60.5	2.9	-2.1	0.0	0.0	20.2	0.0	-0.0	-0.4	-0.4
8	536372.00	4828025.02	365.65	0	4000	73.0	73.0	0.0	0.0	60.5	9.8	-2.1	0.0	0.0	22.0	0.0	-0.0	-17.3	-17.3
9	536372.00	4828025.02	365.65	0	8000	62.9	62.9	0.0	0.0	60.5	35.0	-2.1	0.0	0.0	23.2	0.0	-0.0	-53.8	-53.8

Point Source, ISO 9613, Name: "Biofilter fan", ID: "S2B"

Nr.	X (m)	Y (m)	Z (m)	Refl.	Freq. (Hz)	LxT dB(A)	LxN dB(A)	K0 (dB)	Dc (dB)	Adiv (dB)	Aatm (dB)	Agr (dB)	Afol (dB)	Ahous (dB)	Abar (dB)	Cmet (dB)	RL (dB)	LrT dB(A)	LrN dB(A)
1	536373.92	4828028.71	365.66	0	32	-39.4	-39.4	0.0	0.0	60.6	0.0	-4.1	0.0	0.0	4.4	0.0	-0.0	100.3	100.3
2	536373.92	4828028.71	365.66	0	63	88.8	88.8	0.0	0.0	60.6	0.0	-4.1	0.0	0.0	5.2	0.0	-0.0	27.0	27.0
3	536373.92	4828028.71	365.66	0	125	91.9	91.9	0.0	0.0	60.6	0.1	1.0	0.0	0.0	6.1	0.0	-0.0	24.0	24.0
4	536373.92	4828028.71	365.66	0	250	79.4	79.4	0.0	0.0	60.6	0.3	-0.7	0.0	0.0	7.6	0.0	-0.0	11.6	11.6
5	536373.92	4828028.71	365.66	0	500	83.8	83.8	0.0	0.0	60.6	0.6	-2.1	0.0	0.0	9.5	0.0	-0.0	15.2	15.2
6	536373.92	4828028.71	365.66	0	1000	83.0	83.0	0.0	0.0	60.6	1.1	-2.1	0.0	0.0	11.6	0.0	-0.0	11.8	11.8
7	536373.92	4828028.71	365.66	0	2000	81.2	81.2	0.0	0.0	60.6	2.9	-2.1	0.0	0.0	14.0	0.0	-0.0	5.7	5.7
8	536373.92	4828028.71	365.66	0	4000	73.0	73.0	0.0	0.0	60.6	9.9	-2.1	0.0	0.0	16.5	0.0	-0.0	-12.0	-12.0
9	536373.92	4828028.71	365.66	0	8000	62.9	62.9	0.0	0.0	60.6	35.4	-2.1	0.0	0.0	18.8	0.0	-0.0	-49.9	-49.9

Point Source, ISO 9613, Name: "Agitator 1", ID: "S4"

Nr.	X (m)	Y (m)	Z (m)	Refl.	Freq. (Hz)	LxT dB(A)	LxN dB(A)	K0 (dB)	Dc (dB)	Adiv (dB)	Aatm (dB)	Agr (dB)	Afol (dB)	Ahous (dB)	Abar (dB)	Cmet (dB)	RL (dB)	LrT dB(A)	LrN dB(A)
1	536331.65	4828009.55	369.56	0	500	82.0	82.0	0.0	0.0	60.3	0.6	-0.7	0.0	0.0	21.1	0.0	-0.0	0.8	0.8

Point Source, ISO 9613, Name: "Agitator 1", ID: "S4"																			
Nr.	X	Y	Z	Refl.	Freq.	LxT	LxN	K0	Dc	Adiv	Aatm	Agr	Afol	Ahous	Abar	Cmet	RL	LrT	LrN
	(m)	(m)	(m)		(Hz)	dB(A)	dB(A)	(dB)	(dB)	(dB)	(dB)	(dB)	(dB)	(dB)	(dB)	(dB)	(dB)	dB(A)	dB(A)
2	536331.65	4828009.55	369.56	1	500	82.0	82.0	0.0	0.0	61.1	0.6	-1.0	0.0	0.0	14.4	0.0	1.0	5.8	5.8

Point Source, ISO 9613, Name: "Agitator 2", ID: "S5"																			
Nr.	X	Y	Z	Refl.	Freq.	LxT	LxN	K0	Dc	Adiv	Aatm	Agr	Afol	Ahous	Abar	Cmet	RL	LrT	LrN
	(m)	(m)	(m)		(Hz)	dB(A)	dB(A)	(dB)	(dB)	(dB)	(dB)	(dB)	(dB)	(dB)	(dB)	(dB)	(dB)	dB(A)	dB(A)
1	536312.63	4827995.86	368.92	0	500	82.0	82.0	0.0	0.0	60.0	0.6	-0.6	0.0	0.0	17.5	0.0	-0.0	4.6	4.6
2	536312.63	4827995.86	368.92	1	500	82.0	82.0	0.0	0.0	61.7	0.7	-1.1	0.0	0.0	25.0	0.0	1.0	-5.2	-5.2

Point Source, ISO 9613, Name: "Agitator 3", ID: "S6"																			
Nr.	X	Y	Z	Refl.	Freq.	LxT	LxN	K0	Dc	Adiv	Aatm	Agr	Afol	Ahous	Abar	Cmet	RL	LrT	LrN
	(m)	(m)	(m)		(Hz)	dB(A)	dB(A)	(dB)	(dB)	(dB)	(dB)	(dB)	(dB)	(dB)	(dB)	(dB)	(dB)	dB(A)	dB(A)
1	536332.71	4827992.63	369.53	0	500	82.0	82.0	0.0	0.0	59.8	0.5	-0.6	0.0	0.0	0.0	0.0	-0.0	22.3	22.3

Point Source, ISO 9613, Name: "Agitator 4", ID: "S7"																			
Nr.	X	Y	Z	Refl.	Freq.	LxT	LxN	K0	Dc	Adiv	Aatm	Agr	Afol	Ahous	Abar	Cmet	RL	LrT	LrN
	(m)	(m)	(m)		(Hz)	dB(A)	dB(A)	(dB)	(dB)	(dB)	(dB)	(dB)	(dB)	(dB)	(dB)	(dB)	(dB)	dB(A)	dB(A)
1	536342.47	4827997.19	369.23	0	500	82.0	82.0	0.0	0.0	59.8	0.5	-0.6	0.0	0.0	18.4	0.0	-0.0	3.8	3.8

Point Source, ISO 9613, Name: "Agitator 5", ID: "S8"																			
Nr.	X	Y	Z	Refl.	Freq.	LxT	LxN	K0	Dc	Adiv	Aatm	Agr	Afol	Ahous	Abar	Cmet	RL	LrT	LrN
	(m)	(m)	(m)		(Hz)	dB(A)	dB(A)	(dB)	(dB)	(dB)	(dB)	(dB)	(dB)	(dB)	(dB)	(dB)	(dB)	dB(A)	dB(A)
1	536360.09	4827985.34	369.74	0	500	82.0	82.0	0.0	0.0	59.4	0.5	-0.6	0.0	0.0	0.0	0.0	-0.0	22.7	22.7

Point Source, ISO 9613, Name: "Agitator 6", ID: "S9"																			
Nr.	X	Y	Z	Refl.	Freq.	LxT	LxN	K0	Dc	Adiv	Aatm	Agr	Afol	Ahous	Abar	Cmet	RL	LrT	LrN
	(m)	(m)	(m)		(Hz)	dB(A)	dB(A)	(dB)	(dB)	(dB)	(dB)	(dB)	(dB)	(dB)	(dB)	(dB)	(dB)	dB(A)	dB(A)
1	536342.19	4827976.06	369.87	0	500	82.0	82.0	0.0	0.0	59.2	0.5	-0.5	0.0	0.0	0.0	0.0	-0.0	22.8	22.8
2	536342.19	4827976.06	369.87	1	500	82.0	82.0	0.0	0.0	59.2	0.5	-0.5	0.0	0.0	0.0	0.0	1.0	21.8	21.8

Point Source, ISO 9613, Name: "Agitator 7", ID: "S10"																			
Nr.	X	Y	Z	Refl.	Freq.	LxT	LxN	K0	Dc	Adiv	Aatm	Agr	Afol	Ahous	Abar	Cmet	RL	LrT	LrN
	(m)	(m)	(m)		(Hz)	dB(A)	dB(A)	(dB)	(dB)	(dB)	(dB)	(dB)	(dB)	(dB)	(dB)	(dB)	(dB)	dB(A)	dB(A)
1	536327.57	4827985.16	368.45	0	500	82.0	82.0	0.0	0.0	59.6	0.5	-0.6	0.0	0.0	17.1	0.0	-0.0	5.3	5.3

Point Source, ISO 9613, Name: "Agitator 8", ID: "S11"																			
Nr.	X	Y	Z	Refl.	Freq.	LxT	LxN	K0	Dc	Adiv	Aatm	Agr	Afol	Ahous	Abar	Cmet	RL	LrT	LrN
	(m)	(m)	(m)		(Hz)	dB(A)	dB(A)	(dB)	(dB)	(dB)	(dB)	(dB)	(dB)	(dB)	(dB)	(dB)	(dB)	dB(A)	dB(A)
1	536336.44	4827966.69	368.58	0	500	82.0	82.0	0.0	0.0	58.9	0.5	-0.4	0.0	0.0	0.0	0.0	-0.0	23.0	23.0

Point Source, ISO 9613, Name: "Agitator 9", ID: "S12"																			
Nr.	X	Y	Z	Refl.	Freq.	LxT	LxN	K0	Dc	Adiv	Aatm	Agr	Afol	Ahous	Abar	Cmet	RL	LrT	LrN
	(m)	(m)	(m)		(Hz)	dB(A)	dB(A)	(dB)	(dB)	(dB)	(dB)	(dB)	(dB)	(dB)	(dB)	(dB)	(dB)	dB(A)	dB(A)
1	536317.58	4827959.11	367.79	0	500	82.0	82.0	0.0	0.0	58.8	0.5	-0.4	0.0	0.0	0.0	0.0	-0.0	23.0	23.0

Point Source, ISO 9613, Name: "Agitator 10", ID: "S13"																			
Nr.	X	Y	Z	Refl.	Freq.	LxT	LxN	K0	Dc	Adiv	Aatm	Agr	Afol	Ahous	Abar	Cmet	RL	LrT	LrN
	(m)	(m)	(m)		(Hz)	dB(A)	dB(A)	(dB)	(dB)	(dB)	(dB)	(dB)	(dB)	(dB)	(dB)	(dB)	(dB)	dB(A)	dB(A)
1	536311.13	4827978.47	368.65	0	500	82.0	82.0	0.0	0.0	59.5	0.5	-0.5	0.0	0.0	15.6	0.0	-0.0	6.9	6.9

Point Source, ISO 9613, Name: "Agitator 11", ID: "S14"																			
Nr.	X	Y	Z	Refl.	Freq.	LxT	LxN	K0	Dc	Adiv	Aatm	Agr	Afol	Ahous	Abar	Cmet	RL	LrT	LrN
	(m)	(m)	(m)		(Hz)	dB(A)	dB(A)	(dB)	(dB)	(dB)	(dB)	(dB)	(dB)	(dB)	(dB)	(dB)	(dB)	dB(A)	dB(A)
1	536327.35	4828019.36	368.87	0	500	93.0	93.0	0.0	0.0	60.6	0.6	-1.0	0.0	0.0	20.0	0.0	-0.0	12.8	12.8
2	536327.35	4828019.36	368.87	1	500	93.0	93.0	0.0	0.0	61.1	0.6	-1.1	0.0	0.0	19.0	0.0	1.0	12.4	12.4

Point Source, ISO 9613, Name: "Agitator 12", ID: "S15"																			
Nr.	X	Y	Z	Refl.	Freq.	LxT	LxN	K0	Dc	Adiv	Aatm	Agr	Afol	Ahous	Abar	Cmet	RL	LrT	LrN
	(m)	(m)	(m)		(Hz)	dB(A)	dB(A)	(dB)	(dB)	(dB)	(dB)	(dB)	(dB)	(dB)	(dB)	(dB)	(dB)	dB(A)	dB(A)
1	536339.00	4828012.25	368.94	0	500	93.0	93.0	0.0	0.0	60.3	0.6	-0.9	0.0	0.0	15.2	0.0	-0.0	17.8	17.8
2	536339.00	4828012.25	368.94	1	500	93.0	93.0	0.0	0.0	60.3	0.6	-0.9	0.0	0.0	20.5	0.0	1.0	11.5	11.5
3	536339.00	4828012.25	368.94	1	500	93.0	93.0	0.0	0.0	60.8	0.6	-1.1	0.0	0.0	19.1	0.0	1.0	12.5	12.5

Point Source, ISO 9613, Name: "Agitator 13", ID: "S16"																			
Nr.	X	Y	Z	Refl.	Freq.	LxT	LxN	K0	Dc	Adiv	Aatm	Agr	Afol	Ahous	Abar	Cmet	RL	LrT	LrN
	(m)	(m)	(m)		(Hz)	dB(A)	dB(A)	(dB)	(dB)	(dB)	(dB)	(dB)	(dB)	(dB)	(dB)	(dB)	(dB)	dB(A)	dB(A)
1	536350.13	4828005.98	369.22	0	500	93.0	93.0	0.0	0.0	60.1	0.6	-0.8	0.0	0.0	14.7	0.0	-0.0	18.4	18.4
2	536350.13	4828005.98	369.22	1	500	93.0	93.0	0.0	0.0	60.4	0.6	-0.9	0.0	0.0	0.0	0.0	1.0	31.9	31.9
3	536350.13	4828005.98	369.22	1	500	93.0	93.0	0.0	0.0	60.6	0.6	-1.0	0.0	0.0	4.9	0.0	1.0	26.9	26.9

Point Source, ISO 9613, Name: "Agitator 17", ID: "S17"																			
Nr.	X	Y	Z	Refl.	Freq.	LxT	LxN	K0	Dc	Adiv	Aatm	Agr	Afol	Ahous	Abar	Cmet	RL	LrT	LrN
	(m)	(m)	(m)		(Hz)	dB(A)	dB(A)	(dB)	(dB)	(dB)	(dB)	(dB)	(dB)	(dB)	(dB)	(dB)	(dB)	dB(A)	dB(A)
1	536351.78	4828004.07	369.22	0	500	93.0	93.0	0.0	0.0	60.0	0.5	-0.7	0.0	0.0	14.0	0.0	-0.0	19.1	19.1
2	536351.78	4828004.07	369.22	1	500	93.0	93.0	0.0	0.0	60.4	0.6	-0.8	0.0	0.0	0.0	0.0	1.0	31.8	31.8

Point Source, ISO 9613, Name: "Radiator", ID: "S18A"																			
Nr.	X	Y	Z	Refl.	Freq.	LxT	LxN	K0	Dc	Adiv	Aatm	Agr	Afol	Ahous	Abar	Cmet	RL	LrT	LrN
	(m)	(m)	(m)		(Hz)	dB(A)	dB(A)	(dB)	(dB)	(dB)	(dB)	(dB)	(dB)	(dB)	(dB)	(dB)	(dB)	dB(A)	dB(A)
1	536418.39	4828045.06	365.00	0	500	97.0	97.0	0.0	0.0	61.1	0.6	-2.2	0.0	0.0	13.1	0.0	-0.0	24.5	24.5

Point Source, ISO 9613, Name: "Radiator", ID: "S18B"																			
Nr.	X	Y	Z	Refl.	Freq.	LxT	LxN	K0	Dc	Adiv	Aatm	Agr	Afol	Ahous	Abar	Cmet	RL	LrT	LrN
	(m)	(m)	(m)		(Hz)	dB(A)	dB(A)	(dB)	(dB)	(dB)	(dB)	(dB)	(dB)	(dB)	(dB)	(dB)	(dB)	dB(A)	dB(A)
1	536424.61	4828044.37	365.00	0	500	97.0	97.0	0.0	0.0	61.1	0.6	-2.2	0.0	0.0	10.8	0.0	-0.0	26.7	26.7

Point Source, ISO 9613, Name: "Discharge", ID: "S19A"																			
Nr.	X	Y	Z	Refl.	Freq.	LxT	LxN	K0	Dc	Adiv	Aatm	Agr	Afol	Ahous	Abar	Cmet	RL	LrT	LrN
	(m)	(m)	(m)		(Hz)	dB(A)	dB(A)	(dB)	(dB)	(dB)	(dB)	(dB)	(dB)	(dB)	(dB)	(dB)	(dB)	dB(A)	dB(A)
1	536418.68	4828042.44	365.50	0	500	102.6	102.6	0.0	0.0	61.0	0.6	-2.1	0.0	0.0	16.8	0.0	-0.0	26.3	26.3

Point Source, ISO 9613, Name: "Discharge", ID: "S19B"																			
Nr.	X	Y	Z	Refl.	Freq.	LxT	LxN	K0	Dc	Adiv	Aatm	Agr	Afol	Ahous	Abar	Cmet	RL	LrT	LrN
	(m)	(m)	(m)		(Hz)	dB(A)	dB(A)	(dB)	(dB)	(dB)	(dB)	(dB)	(dB)	(dB)	(dB)	(dB)	(dB)	dB(A)	dB(A)
1	536423.48	4828041.86	365.50	0	500	102.6	102.6	0.0	0.0	61.0	0.6	-2.1	0.0	0.0	16.5	0.0	-0.0	26.6	26.6

Point Source, ISO 9613, Name: "Intake", ID: "S20A"																			
Nr.	X	Y	Z	Refl.	Freq.	LxT	LxN	K0	Dc	Adiv	Aatm	Agr	Afol	Ahous	Abar	Cmet	RL	LrT	LrN
	(m)	(m)	(m)		(Hz)	dB(A)	dB(A)	(dB)	(dB)	(dB)	(dB)	(dB)	(dB)	(dB)	(dB)	(dB)	(dB)	dB(A)	dB(A)
1	536417.36	4828029.73	369.55	0	500	102.6	102.6	0.0	0.0	60.6	0.6	-1.0	0.0	0.0	4.8	0.0	-0.0	37.6	37.6

Point Source, ISO 9613, Name: "Intake", ID: "S20B"																			
Nr.	X	Y	Z	Refl.	Freq.	LxT	LxN	K0	Dc	Adiv	Aatm	Agr	Afol	Ahous	Abar	Cmet	RL	LrT	LrN
	(m)	(m)	(m)		(Hz)	dB(A)	dB(A)	(dB)	(dB)	(dB)	(dB)	(dB)	(dB)	(dB)	(dB)	(dB)	(dB)	dB(A)	dB(A)
1	536422.07	4828029.14	369.55	0	500	102.6	102.6	0.0	0.0	60.6	0.6	-1.0	0.0	0.0	4.8	0.0	-0.0	37.6	37.6

Point Source, ISO 9613, Name: "Transformer", ID: "S21"																			
Nr.	X	Y	Z	Refl.	Freq.	LxT	LxN	K0	Dc	Adiv	Aatm	Agr	Afol	Ahous	Abar	Cmet	RL	LrT	LrN
	(m)	(m)	(m)		(Hz)	dB(A)	dB(A)	(dB)	(dB)	(dB)	(dB)	(dB)	(dB)	(dB)	(dB)	(dB)	(dB)	dB(A)	dB(A)
1	536427.50	4828024.94	365.49	0	32	37.6	37.6	0.0	0.0	60.5	0.0	-3.9	0.0	0.0	4.8	0.0	-0.0	-23.8	-23.8
2	536427.50	4828024.94	365.49	0	63	56.8	56.8	0.0	0.0	60.5	0.0	-3.9	0.0	0.0	4.8	0.0	-0.0	-4.6	-4.6
3	536427.50	4828024.94	365.49	0	125	68.9	68.9	0.0	0.0	60.5	0.1	1.2	0.0	0.0	3.6	0.0	-0.0	3.5	3.5
4	536427.50	4828024.94	365.49	0	250	71.4	71.4	0.0	0.0	60.5	0.3	-0.6	0.0	0.0	4.8	0.0	-0.0	6.4	6.4
5	536427.50	4828024.94	365.49	0	500	76.8	76.8	0.0	0.0	60.5	0.6	-2.0	0.0	0.0	4.8	0.0	-0.0	12.9	12.9
6	536427.50	4828024.94	365.49	0	1000	74.0	74.0	0.0	0.0	60.5	1.1	-2.0	0.0	0.0	4.8	0.0	-0.0	9.6	9.6
7	536427.50	4828024.94	365.49	0	2000	70.2	70.2	0.0	0.0	60.5	2.9	-2.0	0.0	0.0	4.8	0.0	-0.0	4.0	4.0
8	536427.50	4828024.94	365.49	0	4000	65.0	65.0	0.0	0.0	60.5	9.8	-2.0	0.0	0.0	4.8	0.0	-0.0	-8.2	-8.2
9	536427.50	4828024.94	365.49	0	8000	55.9	55.9	0.0	0.0	60.5	35.0	-2.0	0.0	0.0	4.8	0.0	-0.0	-42.4	-42.4

Point Source, ISO 9613, Name: "Radiator2", ID: "SR"																			
Nr.	X	Y	Z	Refl.	Freq.	LxT	LxN	K0	Dc	Adiv	Aatm	Agr	Afol	Ahous	Abar	Cmet	RL	LrT	LrN
	(m)	(m)	(m)		(Hz)	dB(A)	dB(A)	(dB)	(dB)	(dB)	(dB)	(dB)	(dB)	(dB)	(dB)	(dB)	(dB)	dB(A)	dB(A)
1	536359.28	4828005.67	365.86	0	32	-8.4	-8.4	0.0	0.0	60.0	0.0	-3.9	0.0	0.0	1.5	0.0	-0.0	-66.0	-66.0
2	536359.28	4828005.67	365.86	0	63	4.8	4.8	0.0	0.0	60.0	0.0	-3.9	0.0	0.0	2.3	0.0	-0.0	-53.7	-53.7
3	536359.28	4828005.67	365.86	0	125	14.9	14.9	0.0	0.0	60.0	0.1	1.2	0.0	0.0	3.0	0.0	-0.0	-49.4	-49.4
4	536359.28	4828005.67	365.86	0	250	22.4	22.4	0.0	0.0	60.0	0.3	-0.5	0.0	0.0	5.3	0.0	-0.0	-42.7	-42.7
5	536359.28	4828005.67	365.86	0	500	27.0	27.0	0.0	0.0	60.0	0.5	-1.9	0.0	0.0	7.7	0.0	-0.0	-30.6	-30.6
6	536359.28	4828005.67	365.86	0	1000	31.0	31.0	0.0	0.0	60.0	1.0	-1.9	0.0	0.0	10.3	0.0	-0.0	-38.4	-38.4
7	536359.28	4828005.67	365.86	0	2000	32.2	32.2	0.0	0.0	60.0	2.7	-1.9	0.0	0.0	13.0	0.0	-0.0	-41.6	-41.6
8	536359.28	4828005.67	365.86	0	4000	32.0	32.0	0.0	0.0	60.0	9.3	-1.9	0.0	0.0	15.8	0.0	-0.0	-51.2	-51.2

Point Source, ISO 9613, Name: "Radiator2", ID: "SR"																			
Nr.	X	Y	Z	Refl.	Freq.	LxT	LxN	K0	Dc	Adiv	Aatm	Agr	Afol	Ahous	Abar	Cmet	RL	LrT	LrN
	(m)	(m)	(m)		(Hz)	dB(A)	dB(A)	(dB)	(dB)	(dB)	(dB)	(dB)	(dB)	(dB)	(dB)	(dB)	(dB)	dB(A)	dB(A)
9	536359.28	4828005.67	365.86	0	8000	29.9	29.9	0.0	0.0	60.0	33.0	-1.9	0.0	0.0	18.4	0.0	-0.0	-79.6	-79.6
10	536359.28	4828005.67	365.86	1	125	14.9	14.9	0.0	0.0	60.1	0.1	1.2	0.0	0.0	5.4	0.0	1.0	-52.9	-52.9
11	536359.28	4828005.67	365.86	1	250	22.4	22.4	0.0	0.0	60.1	0.3	-0.6	0.0	0.0	8.5	0.0	1.0	-47.0	-47.0
12	536359.28	4828005.67	365.86	1	500	97.0	97.0	0.0	0.0	60.1	0.6	-1.9	0.0	0.0	11.6	0.0	1.0	25.7	25.7
13	536359.28	4828005.67	365.86	1	1000	31.0	31.0	0.0	0.0	60.1	1.1	-1.9	0.0	0.0	14.9	0.0	1.0	-44.1	-44.1
14	536359.28	4828005.67	365.86	1	2000	32.2	32.2	0.0	0.0	60.1	2.8	-1.9	0.0	0.0	17.9	0.0	1.0	-47.7	-47.7
15	536359.28	4828005.67	365.86	1	4000	32.0	32.0	0.0	0.0	60.1	9.4	-1.9	0.0	0.0	20.9	0.0	1.0	-57.5	-57.5
16	536359.28	4828005.67	365.86	1	8000	29.9	29.9	0.0	0.0	60.1	33.4	-1.9	0.0	0.0	23.9	0.0	1.0	-86.6	-86.6

Line Source, ISO 9613, Name: "Truck Route", ID: "Truck Route"																			
Nr.	X	Y	Z	Refl.	Freq.	LxT	LxN	K0	Dc	Adiv	Aatm	Agr	Afol	Ahous	Abar	Cmet	RL	LrT	LrN
	(m)	(m)	(m)		(Hz)	dB(A)	dB(A)	(dB)	(dB)	(dB)	(dB)	(dB)	(dB)	(dB)	(dB)	(dB)	(dB)	dB(A)	dB(A)
1	536375.74	4827986.70	364.36	0	500	101.7	91.7	0.0	0.0	59.3	0.5	-1.6	0.0	0.0	0.0	0.0	-0.0	43.4	33.4
2	536297.45	4827982.67	362.75	0	500	96.2	86.2	0.0	0.0	59.8	0.5	-1.6	0.0	0.0	0.0	0.0	-0.0	37.4	27.4
3	536302.75	4828005.89	363.62	0	500	96.4	86.4	0.0	0.0	60.4	0.6	-1.8	0.0	0.0	12.1	0.0	-0.0	25.1	15.1
4	536309.52	4828035.53	364.73	0	500	98.2	88.2	0.0	0.0	61.2	0.6	-2.0	0.0	0.0	17.7	0.0	-0.0	20.7	10.7
5	536340.78	4827949.56	362.40	0	500	99.0	89.0	0.0	0.0	58.3	0.5	-0.4	0.0	0.0	0.0	0.0	-0.0	40.7	30.7
6	536364.24	4827939.17	362.76	0	500	94.7	84.7	0.0	0.0	57.7	0.4	-0.1	0.0	0.0	0.0	0.0	-0.0	36.6	26.6
7	536315.31	4828053.07	365.40	0	500	88.0	78.0	0.0	0.0	61.6	0.7	-2.2	0.0	0.0	17.3	0.0	-0.0	10.6	0.6
8	536318.19	4828052.57	365.40	0	500	86.3	76.3	0.0	0.0	61.5	0.7	-2.2	0.0	0.0	16.7	0.0	-0.0	9.6	-0.4
9	536321.64	4828051.97	365.40	0	500	89.2	79.2	0.0	0.0	61.5	0.7	-2.2	0.0	0.0	17.1	0.0	-0.0	12.1	2.1
10	536324.47	4828051.49	365.40	0	500	82.9	72.9	0.0	0.0	61.5	0.6	-2.2	0.0	0.0	16.5	0.0	-0.0	6.5	-3.5
11	536327.01	4828051.05	365.40	0	500	88.6	78.6	0.0	0.0	61.4	0.6	-2.1	0.0	0.0	16.8	0.0	-0.0	11.9	1.9
12	536332.44	4828050.11	365.40	0	500	90.9	80.9	0.0	0.0	61.4	0.6	-2.1	0.0	0.0	19.8	0.0	-0.0	11.3	1.3
13	536336.66	4828049.39	365.40	0	500	84.7	74.7	0.0	0.0	61.3	0.6	-2.1	0.0	0.0	20.1	0.0	-0.0	4.7	-5.3
14	536342.91	4828048.31	365.40	0	500	93.0	83.0	0.0	0.0	61.3	0.6	-2.1	0.0	0.0	19.8	0.0	-0.0	13.4	3.4
15	536349.19	4828047.22	365.40	0	500	84.8	74.8	0.0	0.0	61.2	0.6	-2.1	0.0	0.0	19.2	0.0	-0.0	5.8	-4.1
16	536350.47	4828046.84	365.41	0	500	82.7	72.7	0.0	0.0	61.2	0.6	-2.1	0.0	0.0	19.1	0.0	-0.0	3.9	-6.1
17	536351.47	4828046.30	365.43	0	500	83.4	73.4	0.0	0.0	61.2	0.6	-2.1	0.0	0.0	18.1	0.0	-0.0	5.6	-4.4
18	536353.52	4828045.19	365.48	0	500	87.9	77.9	0.0	0.0	61.2	0.6	-2.1	0.0	0.0	18.0	0.0	-0.0	10.3	0.3
19	536358.21	4828042.66	365.59	0	500	91.1	81.1	0.0	0.0	61.1	0.6	-2.1	0.0	0.0	17.6	0.0	-0.0	14.0	4.0
20	536362.41	4828040.39	365.69	0	500	86.2	76.2	0.0	0.0	61.0	0.6	-2.1	0.0	0.0	16.8	0.0	-0.0	9.9	-0.1
21	536364.17	4828039.44	365.73	0	500	84.7	74.7	0.0	0.0	61.0	0.6	-2.1	0.0	0.0	16.5	0.0	-0.0	8.7	-1.3
22	536365.70	4828038.62	365.77	0	500	85.1	75.1	0.0	0.0	60.9	0.6	-2.1	0.0	0.0	16.3	0.0	-0.0	9.4	-0.6
23	536367.57	4828037.61	365.81	0	500	86.4	76.4	0.0	0.0	60.9	0.6	-2.0	0.0	0.0	15.3	0.0	-0.0	11.6	1.6
24	536369.09	4828036.79	365.85	0	500	82.6	72.6	0.0	0.0	60.9	0.6	-2.0	0.0	0.0	14.5	0.0	-0.0	8.7	-1.3
25	536370.61	4828035.97	365.88	0	500	86.4	76.4	0.0	0.0	60.8	0.6	-2.0	0.0	0.0	12.8	0.0	-0.0	14.1	4.1
26	536372.22	4828035.10	365.92	0	500	83.5	73.5	0.0	0.0	60.8	0.6	-2.0	0.0	0.0	10.2	0.0	-0.0	13.8	3.8
27	536373.79	4828034.25	365.96	0	500	86.2	76.2	0.0	0.0	60.8	0.6	-2.0	0.0	0.0	6.4	0.0	-0.0	20.4	10.4
28	536376.29	4828032.90	366.02	0	500	87.8	77.8	0.0	0.0	60.8	0.6	-2.0	0.0	0.0	13.3	0.0	-0.0	15.2	5.1
29	536299.61	4827967.09	362.80	0	500	93.6	83.6	0.0	0.0	59.3	0.5	-1.1	0.0	0.0	0.0	0.0	-0.0	34.8	24.8
30	536314.70	4827955.16	362.47	0	500	92.6	82.6	0.0	0.0	58.8	0.5	-0.7	0.0	0.0	0.0	0.0	-0.0	34.0	24.0
31	536378.52	4828031.69	366.04	0	500	85.0	75.0	0.0	0.0	60.7	0.6	-2.0	0.0	0.0	6.6	0.0	-0.0	19.0	9.0
32	536384.20	4828028.51	365.96	0	500	93.0	83.0	0.0	0.0	60.6	0.6	-2.0	0.0	0.0	0.0	0.0	-0.0	33.8	23.8
33	536307.59	4827960.68	363.09	0	500	91.5	81.5	0.0	0.0	59.0	0.5	-0.9	0.0	0.0	0.0	0.0	-0.0	32.8	22.8

Receiver

Name: POR 3 - Township Road 14 Residence

ID:

X: 536240.66

Y: 4828258.81

Z: 364.29

Point Source, ISO 9613, Name: "Engine # 1", ID: "S1A"

Nr.	X (m)	Y (m)	Z (m)	Refl.	Freq. (Hz)	LxT dB(A)	LxN dB(A)	K0 (dB)	Dc (dB)	Adiv (dB)	Aatm (dB)	Agr (dB)	Afol (dB)	Ahous (dB)	Abar (dB)	Cmet (dB)	RL (dB)	LrT dB(A)	LrN dB(A)
1	536418.76	4828039.34	372.55	0	32	66.6	66.6	0.0	0.0	60.0	0.0	-3.0	0.0	0.0	0.0	0.0	-0.0	9.6	9.6
2	536418.76	4828039.34	372.55	0	63	101.8	101.8	0.0	0.0	60.0	0.0	-3.0	0.0	0.0	0.0	0.0	-0.0	44.7	44.7
3	536418.76	4828039.34	372.55	0	125	109.9	109.9	0.0	0.0	60.0	0.1	3.2	0.0	0.0	0.0	0.0	-0.0	46.5	46.5
4	536418.76	4828039.34	372.55	0	250	115.4	115.4	0.0	0.0	60.0	0.3	1.3	0.0	0.0	0.0	0.0	-0.0	53.8	53.8
5	536418.76	4828039.34	372.55	0	500	115.8	115.8	0.0	0.0	60.0	0.6	-0.1	0.0	0.0	0.0	0.0	-0.0	55.3	55.3
6	536418.76	4828039.34	372.55	0	1000	116.0	116.0	0.0	0.0	60.0	1.0	-0.1	0.0	0.0	0.0	0.0	-0.0	55.0	55.0
7	536418.76	4828039.34	372.55	0	2000	120.2	120.2	0.0	0.0	60.0	2.7	-0.1	0.0	0.0	0.0	0.0	-0.0	57.5	57.5
8	536418.76	4828039.34	372.55	0	4000	121.0	121.0	0.0	0.0	60.0	9.3	-0.1	0.0	0.0	0.0	0.0	-0.0	51.8	51.8
9	536418.76	4828039.34	372.55	0	8000	116.9	116.9	0.0	0.0	60.0	33.0	-0.1	0.0	0.0	0.0	0.0	-0.0	23.9	23.9
10	536418.76	4828039.34	372.55	1	500	115.8	115.8	0.0	0.0	61.2	0.6	-0.6	0.0	0.0	0.0	0.0	1.0	53.5	53.5
11	536418.76	4828039.34	372.55	1	1000	116.0	116.0	0.0	0.0	61.2	1.2	-0.6	0.0	0.0	0.0	0.0	1.0	53.2	53.2
12	536418.76	4828039.34	372.55	1	2000	120.2	120.2	0.0	0.0	61.2	3.1	-0.6	0.0	0.0	0.0	0.0	1.0	55.4	55.4
13	536418.76	4828039.34	372.55	1	4000	121.0	121.0	0.0	0.0	61.2	10.6	-0.6	0.0	0.0	0.0	0.0	1.0	48.7	48.7
14	536418.76	4828039.34	372.55	1	8000	116.9	116.9	0.0	0.0	61.2	37.9	-0.6	0.0	0.0	0.0	0.0	1.0	17.3	17.3

Point Source, ISO 9613, Name: "Engine # 2", ID: "S1B"

Nr.	X (m)	Y (m)	Z (m)	Refl.	Freq. (Hz)	LxT dB(A)	LxN dB(A)	K0 (dB)	Dc (dB)	Adiv (dB)	Aatm (dB)	Agr (dB)	Afol (dB)	Ahous (dB)	Abar (dB)	Cmet (dB)	RL (dB)	LrT dB(A)	LrN dB(A)
1	536422.75	4828038.88	372.55	0	32	66.6	66.6	0.0	0.0	60.1	0.0	-3.0	0.0	0.0	0.0	0.0	-0.0	9.5	9.5
2	536422.75	4828038.88	372.55	0	63	101.8	101.8	0.0	0.0	60.1	0.0	-3.0	0.0	0.0	0.0	0.0	-0.0	44.6	44.6
3	536422.75	4828038.88	372.55	0	125	109.9	109.9	0.0	0.0	60.1	0.1	3.2	0.0	0.0	0.0	0.0	-0.0	46.4	46.4
4	536422.75	4828038.88	372.55	0	250	115.4	115.4	0.0	0.0	60.1	0.3	1.3	0.0	0.0	0.0	0.0	-0.0	53.7	53.7
5	536422.75	4828038.88	372.55	0	500	115.8	115.8	0.0	0.0	60.1	0.6	-0.1	0.0	0.0	0.0	0.0	-0.0	55.2	55.2
6	536422.75	4828038.88	372.55	0	1000	116.0	116.0	0.0	0.0	60.1	1.0	-0.1	0.0	0.0	0.0	0.0	-0.0	54.9	54.9
7	536422.75	4828038.88	372.55	0	2000	120.2	120.2	0.0	0.0	60.1	2.8	-0.1	0.0	0.0	0.0	0.0	-0.0	57.4	57.4
8	536422.75	4828038.88	372.55	0	4000	121.0	121.0	0.0	0.0	60.1	9.4	-0.1	0.0	0.0	0.0	0.0	-0.0	51.6	51.6
9	536422.75	4828038.88	372.55	0	8000	116.9	116.9	0.0	0.0	60.1	33.4	-0.1	0.0	0.0	0.0	0.0	-0.0	23.5	23.5
10	536422.75	4828038.88	372.55	1	500	115.8	115.8	0.0	0.0	61.3	0.6	-0.6	0.0	0.0	0.0	0.0	1.0	53.4	53.4
11	536422.75	4828038.88	372.55	1	1000	116.0	116.0	0.0	0.0	61.3	1.2	-0.6	0.0	0.0	0.0	0.0	1.0	53.1	53.1
12	536422.75	4828038.88	372.55	1	2000	120.2	120.2	0.0	0.0	61.3	3.2	-0.6	0.0	0.0	0.0	0.0	1.0	55.3	55.3
13	536422.75	4828038.88	372.55	1	4000	121.0	121.0	0.0	0.0	61.3	10.8	-0.6	0.0	0.0	0.0	0.0	1.0	48.5	48.5
14	536422.75	4828038.88	372.55	1	8000	116.9	116.9	0.0	0.0	61.3	38.4	-0.6	0.0	0.0	0.0	0.0	1.0	16.8	16.8

Point Source, ISO 9613, Name: "Biofilter fan", ID: "S2A"

Nr.	X (m)	Y (m)	Z (m)	Refl.	Freq. (Hz)	LxT dB(A)	LxN dB(A)	K0 (dB)	Dc (dB)	Adiv (dB)	Aatm (dB)	Agr (dB)	Afol (dB)	Ahous (dB)	Abar (dB)	Cmet (dB)	RL (dB)	LrT dB(A)	LrN dB(A)
1	536372.00	4828025.02	365.65	0	32	-39.4	-39.4	0.0	0.0	59.6	0.0	-3.8	0.0	0.0	2.8	0.0	-0.0	-98.0	-98.0
2	536372.00	4828025.02	365.65	0	63	88.8	88.8	0.0	0.0	59.6	0.0	-3.8	0.0	0.0	3.4	0.0	-0.0	29.6	29.6
3	536372.00	4828025.02	365.65	0	125	91.9	91.9	0.0	0.0	59.6	0.1	2.6	0.0	0.0	2.0	0.0	-0.0	27.7	27.7
4	536372.00	4828025.02	365.65	0	250	79.4	79.4	0.0	0.0	59.6	0.3	2.2	0.0	0.0	3.0	0.0	-0.0	14.4	14.4
5	536372.00	4828025.02	365.65	0	500	83.8	83.8	0.0	0.0	59.6	0.5	-0.4	0.0	0.0	5.8	0.0	-0.0	18.2	18.2
6	536372.00	4828025.02	365.65	0	1000	83.0	83.0	0.0	0.0	59.6	1.0	-1.0	0.0	0.0	7.1	0.0	-0.0	16.3	16.3
7	536372.00	4828025.02	365.65	0	2000	81.2	81.2	0.0	0.0	59.6	2.6	-1.0	0.0	0.0	8.9	0.0	-0.0	11.2	11.2
8	536372.00	4828025.02	365.65	0	4000	73.0	73.0	0.0	0.0	59.6	8.8	-1.0	0.0	0.0	11.1	0.0	-0.0	-5.4	-5.4
9	536372.00	4828025.02	365.65	0	8000	62.9	62.9	0.0	0.0	59.6	31.3	-1.0	0.0	0.0	13.6	0.0	-0.0	-40.6	-40.6
10	536372.00	4828025.02	365.65	1	8000	62.9	62.9	0.0	0.0	61.8	40.5	-2.2	0.0	0.0	25.0	0.0	1.0	-63.3	-63.3
11	536372.00	4828025.02	365.65	1	125	91.9	91.9	0.0	0.0	59.6	0.1	2.3	0.0	0.0	2.6	0.0	1.0	26.2	26.2
12	536372.00	4828025.02	365.65	1	250	79.4	79.4	0.0	0.0	59.6	0.3	1.6	0.0	0.0	3.6	0.0	1.0	13.3	13.3
13	536372.00	4828025.02	365.65	1	500	83.8	83.8	0.0	0.0	59.6	0.5	-0.7	0.0	0.0	5.9	0.0	1.0	17.4	17.4
14	536372.00	4828025.02	365.65	1	1000	83.0	83.0	0.0	0.0	59.6	1.0	-1.1	0.0	0.0	7.2	0.0	1.0	15.3	15.3
15	536372.00	4828025.02	365.65	1	2000	81.2	81.2	0.0	0.0	59.6	2.6	-1.2	0.0	0.0	9.0	0.0	1.0	10.1	10.1
16	536372.00	4828025.02	365.65	1	4000	73.0	73.0	0.0	0.0	59.6	8.9	-1.2	0.0	0.0	11.2	0.0	1.0	-6.5	-6.5
17	536372.00	4828025.02	365.65	1	8000	62.9	62.9	0.0	0.0	59.6	31.6	-1.2	0.0	0.0	13.7	0.0	1.0	-41.9	-41.9

Point Source, ISO 9613, Name: "Biofilter fan", ID: "S2A"																			
Nr.	X	Y	Z	Refl.	Freq.	LxT	LxN	K0	Dc	Adiv	Aatm	Agr	Afol	Ahous	Abar	Cmet	RL	LrT	LrN
	(m)	(m)	(m)		(Hz)	dB(A)	dB(A)	(dB)	(dB)	(dB)	(dB)	(dB)	(dB)	(dB)	(dB)	(dB)	(dB)	dB(A)	dB(A)
18	536372.00	4828025.02	365.65	1	125	91.9	91.9	0.0	0.0	59.8	0.1	1.7	0.0	0.0	10.8	0.0	1.0	18.4	18.4
19	536372.00	4828025.02	365.65	1	250	79.4	79.4	0.0	0.0	59.8	0.3	0.2	0.0	0.0	16.2	0.0	1.0	1.9	1.9
20	536372.00	4828025.02	365.65	1	500	83.8	83.8	0.0	0.0	59.8	0.5	-1.3	0.0	0.0	19.8	0.0	1.0	4.0	4.0
21	536372.00	4828025.02	365.65	1	1000	83.0	83.0	0.0	0.0	59.8	1.0	-1.4	0.0	0.0	22.9	0.0	1.0	-0.3	-0.3
22	536372.00	4828025.02	365.65	1	2000	81.2	81.2	0.0	0.0	59.8	2.7	-1.4	0.0	0.0	25.0	0.0	1.0	-5.9	-5.9
23	536372.00	4828025.02	365.65	1	4000	73.0	73.0	0.0	0.0	59.8	9.1	-1.4	0.0	0.0	25.0	0.0	1.0	-20.5	-20.5
24	536372.00	4828025.02	365.65	1	8000	62.9	62.9	0.0	0.0	59.8	32.3	-1.4	0.0	0.0	25.0	0.0	1.0	-53.8	-53.8

Point Source, ISO 9613, Name: "Biofilter fan", ID: "S2B"																			
Nr.	X	Y	Z	Refl.	Freq.	LxT	LxN	K0	Dc	Adiv	Aatm	Agr	Afol	Ahous	Abar	Cmet	RL	LrT	LrN
	(m)	(m)	(m)		(Hz)	dB(A)	dB(A)	(dB)	(dB)	(dB)	(dB)	(dB)	(dB)	(dB)	(dB)	(dB)	(dB)	dB(A)	dB(A)
1	536373.92	4828028.71	365.66	0	32	-39.4	-39.4	0.0	0.0	59.5	0.0	-3.8	0.0	0.0	0.0	0.0	-0.0	-95.1	-95.1
2	536373.92	4828028.71	365.66	0	63	88.8	88.8	0.0	0.0	59.5	0.0	-3.8	0.0	0.0	0.0	0.0	-0.0	33.1	33.1
3	536373.92	4828028.71	365.66	0	125	91.9	91.9	0.0	0.0	59.5	0.1	2.8	0.0	0.0	0.0	0.0	-0.0	29.5	29.5
4	536373.92	4828028.71	365.66	0	250	79.4	79.4	0.0	0.0	59.5	0.3	2.7	0.0	0.0	0.0	0.0	-0.0	16.9	16.9
5	536373.92	4828028.71	365.66	0	500	83.8	83.8	0.0	0.0	59.5	0.5	-0.1	0.0	0.0	0.0	0.0	-0.0	23.9	23.9
6	536373.92	4828028.71	365.66	0	1000	83.0	83.0	0.0	0.0	59.5	1.0	-0.9	0.0	0.0	0.0	0.0	-0.0	23.4	23.4
7	536373.92	4828028.71	365.66	0	2000	81.2	81.2	0.0	0.0	59.5	2.6	-0.9	0.0	0.0	0.0	0.0	-0.0	20.1	20.1
8	536373.92	4828028.71	365.66	0	4000	73.0	73.0	0.0	0.0	59.5	8.7	-0.9	0.0	0.0	0.0	0.0	-0.0	5.7	5.7
9	536373.92	4828028.71	365.66	0	8000	62.9	62.9	0.0	0.0	59.5	31.1	-0.9	0.0	0.0	0.0	0.0	-0.0	-26.8	-26.8
10	536373.92	4828028.71	365.66	1	500	83.8	83.8	0.0	0.0	59.7	0.5	-0.9	0.0	0.0	6.9	0.0	1.0	16.6	16.6
11	536373.92	4828028.71	365.66	1	1000	83.0	83.0	0.0	0.0	59.7	1.0	-1.3	0.0	0.0	8.5	0.0	1.0	14.0	14.0
12	536373.92	4828028.71	365.66	1	2000	81.2	81.2	0.0	0.0	59.7	2.6	-1.3	0.0	0.0	10.5	0.0	1.0	8.6	8.6
13	536373.92	4828028.71	365.66	1	4000	73.0	73.0	0.0	0.0	59.7	8.9	-1.3	0.0	0.0	12.9	0.0	1.0	-8.3	-8.3
14	536373.92	4828028.71	365.66	1	8000	62.9	62.9	0.0	0.0	59.7	31.9	-1.3	0.0	0.0	15.6	0.0	1.0	-44.0	-44.0
15	536373.92	4828028.71	365.66	1	250	79.4	79.4	0.0	0.0	59.9	0.3	-0.1	0.0	0.0	12.1	0.0	1.0	6.2	6.2
16	536373.92	4828028.71	365.66	1	500	83.8	83.8	0.0	0.0	59.9	0.5	-1.5	0.0	0.0	15.4	0.0	1.0	8.5	8.5
17	536373.92	4828028.71	365.66	1	1000	83.0	83.0	0.0	0.0	59.9	1.0	-1.5	0.0	0.0	18.5	0.0	1.0	4.1	4.1
18	536373.92	4828028.71	365.66	1	2000	81.2	81.2	0.0	0.0	59.9	2.7	-1.5	0.0	0.0	21.5	0.0	1.0	-2.3	-2.3
19	536373.92	4828028.71	365.66	1	4000	73.0	73.0	0.0	0.0	59.9	9.1	-1.5	0.0	0.0	24.5	0.0	1.0	-20.0	-20.0
20	536373.92	4828028.71	365.66	1	8000	62.9	62.9	0.0	0.0	59.9	32.6	-1.5	0.0	0.0	25.0	0.0	1.0	-54.1	-54.1
21	536373.92	4828028.71	365.66	1	500	83.8	83.8	0.0	0.0	59.6	0.5	-0.4	0.0	0.0	4.8	0.0	1.0	18.3	18.3
22	536373.92	4828028.71	365.66	1	1000	83.0	83.0	0.0	0.0	59.6	1.0	-1.0	0.0	0.0	4.8	0.0	1.0	17.7	17.7
23	536373.92	4828028.71	365.66	1	2000	81.2	81.2	0.0	0.0	59.6	2.6	-1.1	0.0	0.0	4.8	0.0	1.0	14.3	14.3
24	536373.92	4828028.71	365.66	1	4000	73.0	73.0	0.0	0.0	59.6	8.8	-1.1	0.0	0.0	4.8	0.0	1.0	-0.1	-0.1
25	536373.92	4828028.71	365.66	1	8000	62.9	62.9	0.0	0.0	59.6	31.4	-1.1	0.0	0.0	4.8	0.0	1.0	-32.8	-32.8

Point Source, ISO 9613, Name: "Agitator 1", ID: "S4"																			
Nr.	X	Y	Z	Refl.	Freq.	LxT	LxN	K0	Dc	Adiv	Aatm	Agr	Afol	Ahous	Abar	Cmet	RL	LrT	LrN
	(m)	(m)	(m)		(Hz)	dB(A)	dB(A)	(dB)	(dB)	(dB)	(dB)	(dB)	(dB)	(dB)	(dB)	(dB)	(dB)	dB(A)	dB(A)
1	536331.65	4828009.55	369.56	0	500	82.0	82.0	0.0	0.0	59.5	0.5	-0.4	0.0	0.0	0.0	0.0	-0.0	22.4	22.4

Point Source, ISO 9613, Name: "Agitator 2", ID: "S5"																			
Nr.	X	Y	Z	Refl.	Freq.	LxT	LxN	K0	Dc	Adiv	Aatm	Agr	Afol	Ahous	Abar	Cmet	RL	LrT	LrN
	(m)	(m)	(m)		(Hz)	dB(A)	dB(A)	(dB)	(dB)	(dB)	(dB)	(dB)	(dB)	(dB)	(dB)	(dB)	(dB)	dB(A)	dB(A)
1	536312.63	4827995.86	368.92	0	500	82.0	82.0	0.0	0.0	59.7	0.5	-0.3	0.0	0.0	4.8	0.0	-0.0	17.3	17.3

Point Source, ISO 9613, Name: "Agitator 3", ID: "S6"																			
Nr.	X	Y	Z	Refl.	Freq.	LxT	LxN	K0	Dc	Adiv	Aatm	Agr	Afol	Ahous	Abar	Cmet	RL	LrT	LrN
	(m)	(m)	(m)		(Hz)	dB(A)	dB(A)	(dB)	(dB)	(dB)	(dB)	(dB)	(dB)	(dB)	(dB)	(dB)	(dB)	dB(A)	dB(A)
1	536332.71	4827992.63	369.53	0	500	82.0	82.0	0.0	0.0	60.0	0.5	-0.6	0.0	0.0	0.0	0.0	-0.0	22.0	22.0

Point Source, ISO 9613, Name: "Agitator 4", ID: "S7"																			
Nr.	X	Y	Z	Refl.	Freq.	LxT	LxN	K0	Dc	Adiv	Aatm	Agr	Afol	Ahous	Abar	Cmet	RL	LrT	LrN
	(m)	(m)	(m)		(Hz)	dB(A)	dB(A)	(dB)	(dB)	(dB)	(dB)	(dB)	(dB)	(dB)	(dB)	(dB)	(dB)	dB(A)	dB(A)
1	536342.47	4827997.19	369.23	0	500	82.0	82.0	0.0	0.0	60.0	0.5	-0.5	0.0	0.0	4.8	0.0	-0.0	17.2	17.2

Point Source, ISO 9613, Name: "Agitator 5", ID: "S8"																			
Nr.	X	Y	Z	Refl.	Freq.	LxT	LxN	K0	Dc	Adiv	Aatm	Agr	Afol	Ahous	Abar	Cmet	RL	LrT	LrN
	(m)	(m)	(m)		(Hz)	dB(A)	dB(A)	(dB)	(dB)	(dB)	(dB)	(dB)	(dB)	(dB)	(dB)	(dB)	(dB)	dB(A)	dB(A)
1	536360.09	4827985.34	369.74	0	500	82.0	82.0	0.0	0.0	60.5	0.6	-0.6	0.0	0.0	22.2	0.0	-0.0	-0.7	-0.7

Point Source, ISO 9613, Name: "Agitator 6", ID: "S9"																			
Nr.	X	Y	Z	Refl.	Freq.	LxT	LxN	K0	Dc	Adiv	Aatm	Agr	Afol	Ahous	Abar	Cmet	RL	LrT	LrN
	(m)	(m)	(m)		(Hz)	dB(A)	dB(A)	(dB)	(dB)	(dB)	(dB)	(dB)	(dB)	(dB)	(dB)	(dB)	(dB)	dB(A)	dB(A)
1	536342.19	4827976.06	369.87	0	500	82.0	82.0	0.0	0.0	60.6	0.6	-0.7	0.0	0.0	23.1	0.0	-0.0	-1.6	-1.6

Point Source, ISO 9613, Name: "Agitator 7", ID: "S10"																			
Nr.	X	Y	Z	Refl.	Freq.	LxT	LxN	K0	Dc	Adiv	Aatm	Agr	Afol	Ahous	Abar	Cmet	RL	LrT	LrN
	(m)	(m)	(m)		(Hz)	dB(A)	dB(A)	(dB)	(dB)	(dB)	(dB)	(dB)	(dB)	(dB)	(dB)	(dB)	(dB)	dB(A)	dB(A)
1	536327.57	4827985.16	368.45	0	500	82.0	82.0	0.0	0.0	60.2	0.6	-0.6	0.0	0.0	19.4	0.0	-0.0	2.4	2.4

Point Source, ISO 9613, Name: "Agitator 8", ID: "S11"																			
Nr.	X	Y	Z	Refl.	Freq.	LxT	LxN	K0	Dc	Adiv	Aatm	Agr	Afol	Ahous	Abar	Cmet	RL	LrT	LrN
	(m)	(m)	(m)		(Hz)	dB(A)	dB(A)	(dB)	(dB)	(dB)	(dB)	(dB)	(dB)	(dB)	(dB)	(dB)	(dB)	dB(A)	dB(A)
1	536336.44	4827966.69	368.58	0	500	82.0	82.0	0.0	0.0	60.8	0.6	-0.7	0.0	0.0	22.7	0.0	-0.0	-1.3	-1.3

Point Source, ISO 9613, Name: "Agitator 9", ID: "S12"																			
Nr.	X	Y	Z	Refl.	Freq.	LxT	LxN	K0	Dc	Adiv	Aatm	Agr	Afol	Ahous	Abar	Cmet	RL	LrT	LrN
	(m)	(m)	(m)		(Hz)	dB(A)	dB(A)	(dB)	(dB)	(dB)	(dB)	(dB)	(dB)	(dB)	(dB)	(dB)	(dB)	dB(A)	dB(A)
1	536317.58	4827959.11	367.79	0	500	82.0	82.0	0.0	0.0	60.8	0.6	-0.5	0.0	0.0	16.3	0.0	-0.0	4.8	4.8

Point Source, ISO 9613, Name: "Agitator 10", ID: "S13"																			
Nr.	X	Y	Z	Refl.	Freq.	LxT	LxN	K0	Dc	Adiv	Aatm	Agr	Afol	Ahous	Abar	Cmet	RL	LrT	LrN
	(m)	(m)	(m)		(Hz)	dB(A)	dB(A)	(dB)	(dB)	(dB)	(dB)	(dB)	(dB)	(dB)	(dB)	(dB)	(dB)	dB(A)	dB(A)
1	536311.13	4827978.47	368.65	0	500	82.0	82.0	0.0	0.0	60.2	0.6	-0.4	0.0	0.0	0.0	0.0	-0.0	21.6	21.6

Point Source, ISO 9613, Name: "Agitator 11", ID: "S14"																			
Nr.	X	Y	Z	Refl.	Freq.	LxT	LxN	K0	Dc	Adiv	Aatm	Agr	Afol	Ahous	Abar	Cmet	RL	LrT	LrN
	(m)	(m)	(m)		(Hz)	dB(A)	dB(A)	(dB)	(dB)	(dB)	(dB)	(dB)	(dB)	(dB)	(dB)	(dB)	(dB)	dB(A)	dB(A)
1	536327.35	4828019.36	368.87	0	500	93.0	93.0	0.0	0.0	59.1	0.5	-0.4	0.0	0.0	0.0	0.0	-0.0	33.8	33.8
2	536327.35	4828019.36	368.87	1	500	93.0	93.0	0.0	0.0	59.1	0.5	-0.4	0.0	0.0	0.0	0.0	1.0	32.7	32.7

Point Source, ISO 9613, Name: "Agitator 12", ID: "S15"																			
Nr.	X	Y	Z	Refl.	Freq.	LxT	LxN	K0	Dc	Adiv	Aatm	Agr	Afol	Ahous	Abar	Cmet	RL	LrT	LrN
	(m)	(m)	(m)		(Hz)	dB(A)	dB(A)	(dB)	(dB)	(dB)	(dB)	(dB)	(dB)	(dB)	(dB)	(dB)	(dB)	dB(A)	dB(A)
1	536339.00	4828012.25	368.94	0	500	93.0	93.0	0.0	0.0	59.5	0.5	-0.5	0.0	0.0	9.6	0.0	-0.0	23.9	23.9

Point Source, ISO 9613, Name: "Agitator 13", ID: "S16"																			
Nr.	X	Y	Z	Refl.	Freq.	LxT	LxN	K0	Dc	Adiv	Aatm	Agr	Afol	Ahous	Abar	Cmet	RL	LrT	LrN
	(m)	(m)	(m)		(Hz)	dB(A)	dB(A)	(dB)	(dB)	(dB)	(dB)	(dB)	(dB)	(dB)	(dB)	(dB)	(dB)	dB(A)	dB(A)
1	536350.13	4828005.98	369.22	0	500	93.0	93.0	0.0	0.0	59.8	0.5	-0.5	0.0	0.0	14.0	0.0	-0.0	19.2	19.2

Point Source, ISO 9613, Name: "Agitator 17", ID: "S17"																			
Nr.	X	Y	Z	Refl.	Freq.	LxT	LxN	K0	Dc	Adiv	Aatm	Agr	Afol	Ahous	Abar	Cmet	RL	LrT	LrN
	(m)	(m)	(m)		(Hz)	dB(A)	dB(A)	(dB)	(dB)	(dB)	(dB)	(dB)	(dB)	(dB)	(dB)	(dB)	(dB)	dB(A)	dB(A)
1	536351.78	4828004.07	369.22	0	500	93.0	93.0	0.0	0.0	59.9	0.5	-0.5	0.0	0.0	13.7	0.0	-0.0	19.3	19.3

Point Source, ISO 9613, Name: "Radiator", ID: "S18A"																			
Nr.	X	Y	Z	Refl.	Freq.	LxT	LxN	K0	Dc	Adiv	Aatm	Agr	Afol	Ahous	Abar	Cmet	RL	LrT	LrN
	(m)	(m)	(m)		(Hz)	dB(A)	dB(A)	(dB)	(dB)	(dB)	(dB)	(dB)	(dB)	(dB)	(dB)	(dB)	(dB)	dB(A)	dB(A)
1	536418.39	4828045.06	365.00	0	500	97.0	97.0	0.0	0.0	59.9	0.5	1.5	0.0	0.0	3.3	0.0	-0.0	31.8	31.8

Point Source, ISO 9613, Name: "Radiator", ID: "S18B"																			
Nr.	X	Y	Z	Refl.	Freq.	LxT	LxN	K0	Dc	Adiv	Aatm	Agr	Afol	Ahous	Abar	Cmet	RL	LrT	LrN
	(m)	(m)	(m)		(Hz)	dB(A)	dB(A)	(dB)	(dB)	(dB)	(dB)	(dB)	(dB)	(dB)	(dB)	(dB)	(dB)	dB(A)	dB(A)
1	536424.61	4828044.37	365.00	0	500	97.0	97.0	0.0	0.0	60.0	0.5	1.5	0.0	0.0	3.3	0.0	-0.0	31.7	31.7
2	536424.61	4828044.37	365.00	1	500	97.0	97.0	0.0	0.0	61.4	0.6	-2.0	0.0	0.0	5.4	0.0	1.0	30.6	30.6
3	536424.61	4828044.37	365.00	1	500	97.0	97.0	0.0	0.0	60.1	0.6	1.0	0.0	0.0	3.8	0.0	1.0	30.5	30.5

Point Source, ISO 9613, Name: "Discharge", ID: "S19A"																			
Nr.	X	Y	Z	Refl.	Freq.	LxT	LxN	K0	Dc	Adiv	Aatm	Agr	Afol	Ahous	Abar	Cmet	RL	LrT	LrN
	(m)	(m)	(m)		(Hz)	dB(A)	dB(A)	(dB)	(dB)	(dB)	(dB)	(dB)	(dB)	(dB)	(dB)	(dB)	(dB)	dB(A)	dB(A)
1	536418.68	4828042.44	365.50	0	500	102.6	102.6	0.0	0.0	59.9	0.5	0.3	0.0	0.0	0.0	0.0	-0.0	41.8	41.8
2	536418.68	4828042.44	365.50	1	500	102.6	102.6	0.0	0.0	61.2	0.6	-1.8	0.0	0.0	24.4	0.0	1.0	17.3	17.3

Line Source, ISO 9613, Name: "Truck Route", ID: "Truck Route"																			
Nr.	X	Y	Z	Refl.	Freq.	LxT	LxN	K0	Dc	Adiv	Aatm	Agr	Afol	Ahous	Abar	Cmet	RL	LrT	LrN
	(m)	(m)	(m)		(Hz)	dB(A)	dB(A)	(dB)	(dB)	(dB)	(dB)	(dB)	(dB)	(dB)	(dB)	(dB)	(dB)	dB(A)	dB(A)
22	536361.28	4827947.41	362.75	0	500	87.8	77.8	0.0	0.0	61.5	0.6	-2.0	0.0	0.0	20.3	0.0	-0.0	7.4	-2.6
23	536358.95	4827947.65	362.71	0	500	83.7	73.7	0.0	0.0	61.4	0.6	-2.0	0.0	0.0	20.4	0.0	-0.0	3.2	-6.8
24	536357.15	4827947.84	362.68	0	500	86.2	76.2	0.0	0.0	61.4	0.6	-2.0	0.0	0.0	20.5	0.0	-0.0	5.6	-4.4
25	536354.86	4827948.08	362.64	0	500	86.1	76.1	0.0	0.0	61.4	0.6	-2.0	0.0	0.0	20.5	0.0	-0.0	5.6	-4.4
26	536351.16	4827948.47	362.58	0	500	89.6	79.6	0.0	0.0	61.4	0.6	-2.0	0.0	0.0	20.2	0.0	-0.0	9.4	-0.6
27	536347.66	4827948.84	362.52	0	500	85.4	75.4	0.0	0.0	61.3	0.6	-2.0	0.0	0.0	18.4	0.0	-0.0	7.0	-3.0
28	536335.74	4827950.10	362.32	0	500	96.0	86.0	0.0	0.0	61.2	0.6	-1.9	0.0	0.0	20.8	0.0	-0.0	15.2	5.2
29	536321.69	4827951.57	362.08	0	500	90.5	80.5	0.0	0.0	61.0	0.6	-1.6	0.0	0.0	16.0	0.0	-0.0	14.4	4.4
30	536383.43	4828028.94	365.97	0	500	93.7	83.7	0.0	0.0	59.6	0.5	-0.3	0.0	0.0	0.0	0.0	-0.0	33.8	23.8
31	536299.61	4827967.09	362.80	0	500	93.6	83.6	0.0	0.0	60.5	0.6	-0.3	0.0	0.0	0.0	0.0	-0.0	32.8	22.8
32	536365.37	4827931.97	362.74	0	500	85.0	75.0	0.0	0.0	61.9	0.7	-2.1	0.0	0.0	18.5	0.0	-0.0	6.0	-4.0
33	536364.10	4827940.04	362.76	0	500	94.2	84.2	0.0	0.0	61.7	0.7	-2.0	0.0	0.0	19.4	0.0	-0.0	14.5	4.5
34	536315.59	4827954.41	362.37	0	500	91.5	81.5	0.0	0.0	60.9	0.6	-1.5	0.0	0.0	9.1	0.0	-0.0	22.4	12.4
35	536311.69	4827957.68	362.81	0	500	86.2	76.2	0.0	0.0	60.8	0.6	-1.3	0.0	0.0	4.8	0.0	-0.0	21.4	11.4
36	536307.59	4827960.68	363.09	0	500	91.5	81.5	0.0	0.0	60.7	0.6	-1.0	0.0	0.0	0.0	0.0	-0.0	31.1	21.1
37	536305.02	4828015.84	363.99	1	500	85.3	75.3	0.0	0.0	59.9	0.5	-1.5	0.0	0.0	14.6	0.0	1.0	10.8	0.8
38	536305.56	4828018.18	364.08	1	500	87.2	77.2	0.0	0.0	59.9	0.5	-1.5	0.0	0.0	14.1	0.0	1.0	13.2	3.1
39	536306.56	4828022.56	364.24	1	500	90.3	80.3	0.0	0.0	59.8	0.5	-1.4	0.0	0.0	4.8	0.0	1.0	25.6	15.6
40	536307.52	4828026.78	364.40	1	500	88.8	78.8	0.0	0.0	59.8	0.5	-1.2	0.0	0.0	4.8	0.0	1.0	24.0	14.0
41	536308.31	4828030.24	364.53	1	500	87.1	77.1	0.0	0.0	59.7	0.5	-1.1	0.0	0.0	4.8	0.0	1.0	22.2	12.2
42	536308.64	4828031.67	364.59	1	500	72.1	62.1	0.0	0.0	59.7	0.5	-1.1	0.0	0.0	4.8	0.0	1.0	7.2	-2.8
43	536388.15	4828022.97	365.77	1	500	83.1	73.1	0.0	0.0	60.1	0.6	-1.1	0.0	0.0	4.8	0.0	1.0	17.7	7.7
44	536388.83	4828024.97	365.85	1	500	84.8	74.8	0.0	0.0	60.3	0.6	-1.5	0.0	0.0	15.6	0.0	1.0	8.9	-1.1
45	536366.17	4828038.36	365.78	1	500	86.8	76.8	0.0	0.0	59.7	0.5	-1.1	0.0	0.0	7.9	0.0	1.0	18.8	8.8
46	536372.56	4828034.92	365.93	1	500	93.2	83.2	0.0	0.0	59.9	0.5	-1.2	0.0	0.0	11.8	0.0	1.0	21.3	11.3
47	536373.39	4828034.47	365.95	1	500	89.4	79.4	0.0	0.0	59.7	0.5	-0.9	0.0	0.0	4.8	0.0	1.0	24.3	14.3
48	536376.65	4828032.71	366.02	1	500	86.5	76.5	0.0	0.0	59.8	0.5	-0.9	0.0	0.0	4.8	0.0	1.0	21.3	11.3
49	536380.01	4828030.85	366.02	1	500	89.7	79.7	0.0	0.0	59.9	0.5	-1.0	0.0	0.0	4.8	0.0	1.0	24.4	14.4
50	536380.07	4828030.82	366.02	1	500	89.8	79.8	0.0	0.0	60.1	0.6	-1.4	0.0	0.0	11.5	0.0	1.0	18.0	8.0